

On the Capacity Region for Index Coding

Fatemeh Arbabjolfaei, Bernd Bandemer, Young-Han Kim, Eren Şaşıoğlu, and Lele Wang

Department of Electrical and Computer Engineering

University of California, San Diego

La Jolla, CA 92093, USA

Email: {farbabjo, bandemer, yhk, esasoglu, lew001}@ucsd.edu

Abstract—A new inner bound on the capacity region of the general index coding problem is established. Unlike most existing bounds that are based on graph theoretic or algebraic tools, the bound relies on a random coding scheme and optimal decoding, and has a simple polymatroidal single-letter expression. The utility of the inner bound is demonstrated by examples that include the capacity region for all index coding problems with up to five messages (there are 9846 nonisomorphic ones).

I. INTRODUCTION

Consider the simple communication problem in Figure 1, which is often referred to as the *index coding* problem. The sender wishes to communicate N messages $M_j \in [1 : 2^{nR_j}]$, $j \in [1 : N]$, to their respective receivers over a common noiseless link that carries n bits X^n . Each receiver $j \in [1 : N]$ has prior knowledge of $M_{\mathcal{A}_j}$, i.e., a subset $\mathcal{A}_j \subseteq [1 : N] \setminus \{j\}$ of the messages. Based on this side information $M_{\mathcal{A}_j}$ and the received bits X^n , receiver j finds the estimate \hat{M}_j of the message M_j . A nontrivial tradeoff arises between the rates R_j , $j \in [1 : N]$, of the messages since receivers with incompatible knowledge compete for the shared broadcast medium.

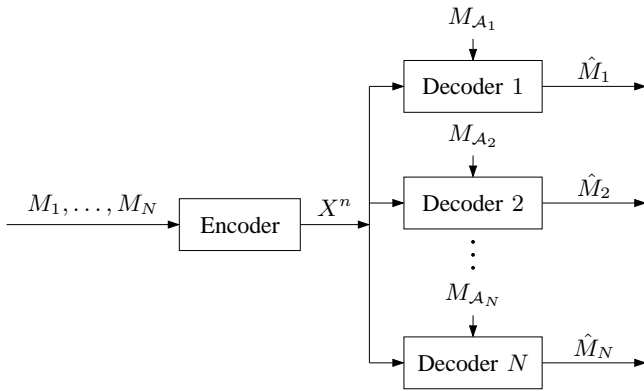

Fig. 1. The index coding problem.

We define a $(2^{nR_1}, \dots, 2^{nR_N}, n)$ code for index coding by an encoder $x^n(m_1, \dots, m_N)$ and N decoders $\hat{m}_j(x^n, m_{\mathcal{A}_j})$, $j \in [1 : N]$. We assume that the message tuple (M_1, \dots, M_N) is uniformly distributed over $[1 : 2^{nR_1}] \times \dots \times [1 : 2^{nR_N}]$, that is, the messages are uniformly distributed and independent of each other. The average probability of error is then defined as $P_e^{(n)} = \mathbf{P}\{(\hat{M}_1, \dots, \hat{M}_N) \neq (M_1, \dots, M_N)\}$. A rate tuple (R_1, \dots, R_N) is said to be achievable if there

exists a sequence of $(2^{nR_1}, \dots, 2^{nR_N}, n)$ codes such that $\lim_{n \rightarrow \infty} P_e^{(n)} = 0$. The capacity region \mathcal{C} of the index coding problem is the closure of the set of achievable rate tuples (R_1, \dots, R_N) . (Similarly, one can define the zero-error capacity region, which is shown in [1] to be identical to the capacity region.) The goal is to find the capacity region and the optimal coding scheme that achieves it.

Note that an index coding problem is fully characterized by the side information sets \mathcal{A}_j , $j \in [1 : N]$. As an example, consider the 3-message index coding problem with $\mathcal{A}_1 = \{2\}$, $\mathcal{A}_2 = \{1, 3\}$, and $\mathcal{A}_3 = \{1\}$. We represent this problem compactly as

$$(1|2), (2|1, 3), (3|1), \quad (1)$$

or as a directed graph (see Figure 2(a)), where nodes represent indices of the messages/receivers and edges represent availability of side information (e.g., the edge $1 \rightarrow 2$ means that side information M_1 is available at receiver 2). In general, an index coding problem $(j|\mathcal{A}_j)$, $j \in [1 : N]$, can be represented by a directed graph $\mathcal{G} = (\mathcal{V}, \mathcal{E})$, where $\mathcal{V} = [1 : N]$ and $(j, k) \in \mathcal{E}$ iff $j \in \mathcal{A}_k$.

Note that the 3-message index coding problem in (1) can be represented as an instance of the network coding problem [2] as illustrated in Figure 2(b). The same observation can be made for any index coding problem; thus, index coding is a special case of network coding.

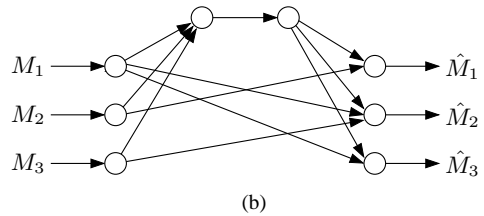
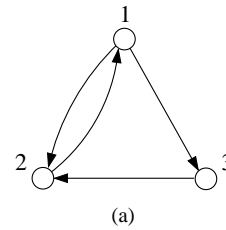

Fig. 2. (a) Directed graph representation. (b) The equivalent network coding problem. Here every edge of the graph can carry up to 1 bit per transmission.

First introduced by Birk and Kol [3] in the context of satellite broadcast communication, the index coding problem has been studied extensively over the past six years in the theoretical computer science and network coding communities with many contributions of combinatorial and algebraic flavors (see, for example, [4]–[16] and the references therein). Our Shannon-theoretic formulation of the problem closely follows that of Maleki, Cadambe, and Jafar [17], who established the capacity region for several interesting classes of index coding problems using interference alignment [18]. Despite all these developments, the capacity region of a general index coding problem is not known.

Confirming Maslow’s axiom [19] “if all you have is a hammer, everything looks like a nail,” we propose a *random coding* approach, in contrast to more advanced coding schemes of an algebraic nature. This approach is more in the spirit of the original paper by Ahlswede, Cai, Li, and Yeung [2], where random coding (binning) was used to establish the network coding theorem. In particular, we develop a *composite coding* scheme based on random coding and establish a corresponding single-letter inner bound on the capacity region.

Instead of mechanical proofs, this paper focuses on basic intuitions behind our coding scheme, which we develop gradually from simpler coding schemes—“flat coding” in Section III and “dual index coding” in Section IV. The composite coding scheme is explained in Section V. The next section discusses known outer bounds on the capacity region.

II. OUTER BOUNDS

We first recall the following outer bound on the capacity region (see, for example, [10] or [20] for a similar bound in the context of a general network coding problem).

Theorem 1: Let $\mathcal{B}_j = [1 : N] \setminus (\{j\} \cup \mathcal{A}_j)$ be the index set of interfering messages at receiver j . If (R_1, \dots, R_N) is achievable, then it must satisfy

$$R_j \leq T_{\{j\} \cup \mathcal{B}_j} - T_{\mathcal{B}_j}, \quad j \in [1 : N],$$

for some $T_{\mathcal{J}}, \mathcal{J} \subseteq [1 : N]$, such that

- 1) $T_{\emptyset} = 0$,
- 2) $T_{[1:N]} = 1$,
- 3) $T_{\mathcal{J}} \leq T_{\mathcal{K}}$ for all $\mathcal{J} \subseteq \mathcal{K} \subseteq [1 : N]$, and
- 4) $T_{\mathcal{J} \cap \mathcal{K}} + T_{\mathcal{J} \cup \mathcal{K}} \leq T_{\mathcal{J}} + T_{\mathcal{K}}$ for all $\mathcal{J}, \mathcal{K} \subseteq [1 : N]$.

The upper bound is established by using Fano’s inequality and setting $T_{\mathcal{J}} = (1/n) H(X^n | M_{\mathcal{J}^c})$. Properties 1–4 are due to the submodularity of entropy.

Recent results by Sun and Jafar [21] indicate that this outer bound is not tight in general. Nevertheless, a relaxed version of the bound is sometimes useful.

Corollary 1: If (R_1, \dots, R_N) is achievable for an index coding problem represented by the directed graph \mathcal{G} , then it must satisfy

$$\sum_{j \in \mathcal{J}} R_j \leq 1$$

for all $\mathcal{J} \subseteq [1 : N]$ for which the subgraph of \mathcal{G} over \mathcal{J} does not contain a directed cycle.

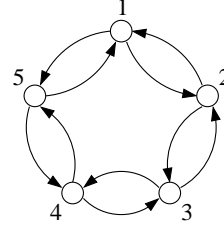

Fig. 3. A graph representation of the 5-message index coding problem.

The following example, due to [15], [17], illustrates that the two outer bounds do not coincide in general.

Example 1: Consider the symmetric five-message index coding problem $(j|j-1, j+1), j \in [1 : 5]$, namely,

$$(1|5, 2), (2|1, 3), (3|2, 4), (4|3, 5), (5|4, 1).$$

The corresponding graph representation is depicted in Figure 3. Applying Corollary 1, we obtain

$$\begin{aligned} R_1 + R_3 &\leq 1, & R_2 + R_4 &\leq 1, & R_3 + R_5 &\leq 1, \\ R_4 + R_1 &\leq 1, & R_5 + R_2 &\leq 1. \end{aligned} \quad (2)$$

In comparison, Theorem 1 leads to the inequality

$$R_1 + R_2 + R_3 + R_4 + R_5 \leq 2, \quad (3)$$

in addition to the five inequalities above. As we discuss in Section V, (2) and (3) characterize the capacity region of this index coding problem.

III. FLAT CODING

Consider the following simple random coding scheme. For each $(m_1, \dots, m_N) \in [1 : 2^{nR_1}] \times \dots \times [1 : 2^{nR_N}]$, generate a codeword $x^n(m_1, \dots, m_N)$ randomly and independently as a Bern(1/2) sequence. To communicate (m_1, \dots, m_N) , the sender transmits $x^n = x^n(m_1, \dots, m_N)$. Receiver j uses simultaneous nonunique decoding [22] and finds the unique $\hat{m}_j \in [1 : 2^{nR_j}]$ such that $x^n(\hat{m}_j, m_{\mathcal{A}_j}, m_{\mathcal{B}_j})$ is jointly typical with (i.e., identical to) the received sequence x^n for some $m_{\mathcal{B}_j}$, where $\mathcal{B}_j = [1 : N] \setminus (\{j\} \cup \mathcal{A}_j)$. Since the codebook generation is “flat” (compared with “layered” superposition coding), simultaneous nonunique decoding is essentially identical to uniquely decoding $(\hat{m}_j, \hat{m}_{\mathcal{B}_j})$ and then discarding the unnecessary part $\hat{m}_{\mathcal{B}_j}$. This flat coding scheme yields the following inner bound.

Proposition 1: A rate tuple (R_1, \dots, R_N) is achievable for the index coding problem $(j|\mathcal{A}_j), j \in [1 : N]$, if

$$R_j + \sum_{k \in \mathcal{B}_j} R_k < 1, \quad j \in [1 : N].$$

As an example, consider the 3-message problem in (1). Under flat coding, receiver 1 finds the unique \hat{m}_1 such that $x^n(\hat{m}_1, m_2, m_3) = x^n$ for some $m_3 \in [1 : 2^{nR_3}]$ and the given side information m_2 . By the packing lemma [23, Sec. 3.4], it can be readily shown that the probability of decoding error for receiver 1 tends to zero as $n \rightarrow \infty$ if

$$R_1 + R_3 < 1. \quad (4)$$

Similarly, we obtain $R_2 < 1$ (an inactive bound) and

$$R_2 + R_3 < 1. \quad (5)$$

By comparing with Theorem 1 (or Corollary 1), it can be easily checked that the rate region characterized by (4) and (5) is indeed the capacity region.

It can be easily verified that for all index coding problems with 1, 2, and 3 messages—there are 1, 3, and 16 non-isomorphic problems [24]—this flat coding scheme (or more generally, time sharing of flat coding over different subsets of messages) achieves the capacity region. Among the 218 four-message index coding problems, time sharing of flat coding over subsets of messages achieves the capacity region for all but three. The following is one of the three exceptions.

Example 2: Consider the 4-message index coding problem

$$(1|4), (2|3, 4), (3|1, 2), (4|2, 3).$$

On the one hand, flat coding yields an inner bound on the capacity region that consists of the rate quadruples (R_1, R_2, R_3, R_4) such that

$$\begin{aligned} R_1 + R_2 + R_3 &< 1, \\ R_1 + R_4 &< 1, \\ R_3 + R_4 &< 1. \end{aligned}$$

It can be verified that this inner bound cannot be improved upon by time sharing over subsets. On the other hand, Theorem 1 (or Corollary 1) yields an outer bound that consists of the rate quadruples (R_1, R_2, R_3, R_4) such that

$$\begin{aligned} R_1 + R_2 &\leq 1, & R_1 + R_3 &\leq 1, \\ R_1 + R_4 &\leq 1, & R_3 + R_4 &\leq 1. \end{aligned} \quad (6)$$

We will see in Section V that this outer bound is tight.

While flat coding is suboptimal in general, the analysis (i.e., the proof of Proposition 1) is trivial and does not rely on any graph theoretic machinery. This observation will be crucial when we generalize the coding scheme subsequently.

IV. DUAL INDEX CODING

Before we move on to a more powerful random coding scheme, we introduce a communication problem (depicted in Figure 4) that is, in some sense, dual to the index coding problem. Here a set of $(2^N - 1)$ senders wish to communicate a message tuple (M_1, \dots, M_N) to a common receiver through a noiseless channel, each encoding a subtuple $M_{\mathcal{J}}$ into a separate index $W_{\mathcal{J}} \in [1 : 2^{n_{S_{\mathcal{J}}}}]$ for all nonempty $\mathcal{J} \subseteq [1 : N]$. What is the capacity region (as a function of the rates $S_{\mathcal{J}}$)?

This problem is a special case of the general multiple access channel (MAC) with correlated messages studied by Han [25]. For the general MAC, superposition coding achieves the capacity region that is characterized by independent auxiliary random variables U_1, \dots, U_N , each corresponding to a message. However, for the dual index coding problem, we can characterize the capacity region explicitly.

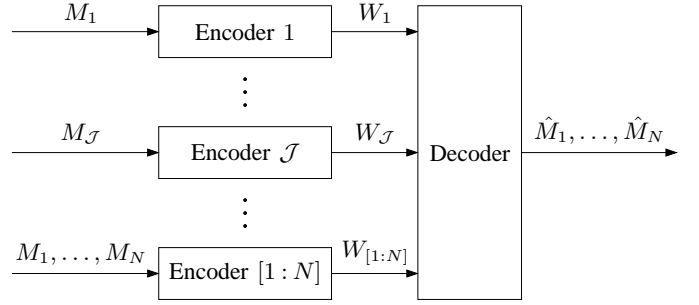

Fig. 4. The dual index coding problem.

Proposition 2: The capacity region of the dual index coding problem is the set of rate tuples (R_1, \dots, R_N) that satisfy

$$\sum_{j \in \mathcal{J}} R_j \leq \sum_{\mathcal{J}' \subseteq [1:N]: \mathcal{J}' \cap \mathcal{J} \neq \emptyset} S_{\mathcal{J}'} \quad (7)$$

for all $\mathcal{J} \subseteq [1 : N]$.

What is perhaps more important than this explicit characterization of the capacity region is the fact that it can be achieved by flat coding, which we will utilize later.

As an example, consider the three-message three-sender dual index coding problem in Figure 5, where $S_{1,2} = 1$, $S_{1,3} = S_{1,2,3} = 2$, and $S_1 = S_2 = S_3 = S_{2,3} = 0$. By (7), the capacity region is the set of rate triples (R_1, R_2, R_3) such that

$$R_1 + R_2 + R_3 \leq 5, \quad R_2 \leq 3, \quad R_3 \leq 4.$$

This can be achieved via flat coding of (M_1, M_2) , (M_1, M_3) , and (M_1, M_2, M_3) , respectively, and simultaneous decoding at the receiver.

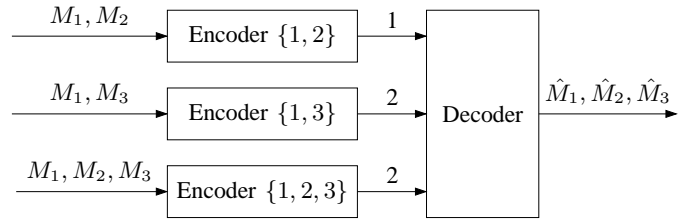

Fig. 5. An instance of dual index coding.

V. COMPOSITE CODING

Equipped with the results in the previous two subsections, we now introduce a layered random coding scheme, which we refer to as *composite coding*. This is best described by an example.

Consider again the 5-message problem in Example 1. In the first step of composite coding, the sender encodes (M_1, M_2) into an index $W_{1,2}$ at rate $S_{1,2}$ using random coding, and similarly encodes (M_2, M_3) , (M_3, M_4) , (M_4, M_5) , and (M_1, M_5) , respectively, into indices $W_{2,3}$, $W_{3,4}$, $W_{4,5}$, and $W_{1,5}$. Equivalently, the sender is decomposed into 5 “virtual” senders, each encoding one of the above pairs of messages (as in

the dual index coding problem). In the second step, the sender uses flat coding to encode the “composite” indices $W_{1,2}, W_{2,3}, W_{3,4}, W_{4,5}, W_{1,5}$. As with encoding, decoding also takes two steps. Each receiver first recovers all composite indices, and then recovers the desired message from the composite indices. For example, receiver 1 recovers $W_{1,2}, W_{1,5}$ (along with other composite indices). Since receiver 1 has side information (M_2, M_5) , it can recover M_1 from $(W_{1,2}, W_{1,5})$ if $R_1 \leq S_{1,2} + S_{1,5}$. Following similar steps for other receivers and incorporating the flat coding rate condition, it can be easily verified that a rate quintuple $(R_1, R_2, R_3, R_4, R_5)$ is achievable if

$$\begin{aligned} R_1 &< S_{1,2} + S_{1,5}, \\ R_2 &< S_{1,2} + S_{2,3}, \\ R_3 &< S_{2,3} + S_{3,4}, \\ R_4 &< S_{3,4} + S_{4,5}, \\ R_5 &< S_{1,5} + S_{4,5} \end{aligned}$$

for some $(S_{1,2}, S_{2,3}, S_{3,4}, S_{4,5}, S_{1,5})$ satisfying $S_{1,2} + S_{2,3} + S_{3,4} + S_{4,5} + S_{1,5} \leq 1$. Fourier–Motzkin elimination [23, Appendix D] of the composite index rates yields the inequalities (2) and (3) that define the outer bound, thus establishing the capacity region.

Now consider the four-message problem in Example 2. In this case, we only use the composite indices $W_{1,4}$ and $W_{1,2,3,4}$ with rates $S_{1,4}$ and $S_{1,2,3,4}$, respectively, and set the rates of the remaining indices to zero. It can be easily verified from Proposition 2 that receiver 1 can recover M_1 if $R_1 < S_{1,4}$; receiver 2 can recover M_2 (and M_1) if $R_1 + R_2 < S_{1,4} + S_{1,2,3,4}$ and $R_2 < S_{1,2,3,4}$; receiver 3 can recover M_3 (and M_4) if $R_3 + R_4 < S_{1,4} + S_{1,2,3,4}$ and $R_3 < S_{1,2,3,4}$; and receiver 4 can recover M_4 (and M_1) if $R_1 + R_4 < S_{1,4} + S_{1,2,3,4}$. Adding the constraint $S_{1,4} + S_{1,2,3,4} \leq 1$ and eliminating $S_{1,4}$ and $S_{1,2,3,4}$, we obtain the inequalities (6) that define the outer bound, thus establishing the capacity region.

In general, we can utilize $(2^N - 1)$ virtual senders to encode N messages. Moreover, the receivers can employ simultaneous nonunique decoding in the second step (or equivalently, ignore

some of the composite indices, as in the examples above). This coding scheme is illustrated in Figure 6. It easily follows from the arguments above that if we allow decoder j to decode a subset \mathcal{K}_j of the messages, then the rates of the composite messages need to belong to the polymatroidal rate region $\mathcal{R}(\mathcal{K}_j | \mathcal{A}_j)$ defined by

$$\sum_{j \in \mathcal{J}} R_j < \sum_{\mathcal{J}' \subseteq \mathcal{K}_j \cup \mathcal{A}_j: \mathcal{J}' \cap \mathcal{J} \neq \emptyset} S_{\mathcal{J}'} \quad (8)$$

for all $\mathcal{J} \subseteq \mathcal{K}_j \setminus \mathcal{A}_j$. Note that this is the capacity region of the dual index coding problem (Proposition 2) with message set \mathcal{K}_j and side information \mathcal{A}_j . Taking the union over all choices of decoding sets \mathcal{K}_j yields the following inner bound, which is the main result of the paper.

Theorem 2 (Composite-coding inner bound): A rate tuple (R_1, \dots, R_N) is achievable for the index coding problem $(j | \mathcal{A}_j)$, $j \in [1 : N]$, if

$$(R_1, \dots, R_N) \in \bigcap_{j \in [1 : N]} \bigcup_{\mathcal{K}_j \subseteq [1 : N]: j \in \mathcal{K}_j} \mathcal{R}(\mathcal{K}_j | \mathcal{A}_j) \quad (9)$$

for some $(S_{\mathcal{J}}: \mathcal{J} \subseteq [1 : N])$ such that $\sum_{\mathcal{J}: \mathcal{J} \not\subseteq \mathcal{A}_j} S_{\mathcal{J}} \leq 1$ for all $j \in [1 : N]$.

At first glance, composite coding seems to be time sharing of flat coding over all subsets of $[1 : N]$. However, it employs the optimal decoding rule that utilizes all composite indices (subsets) that are relevant to the desired message. As such, the corresponding rate region has a very similar form as the optimal rate region for interference networks with random coding [26].

Using the polco tool for polyhedral computations [27], we have computed the composite-coding inner bound and the outer bound in Theorem 1 for all 9608 nonisomorphic five-message index coding problems [24]. In all cases, inner and outer bounds agree, establishing the capacity region.

To further demonstrate the utility of composite coding, we revisit the following example in [17].

Example 3: Consider the N -message *symmetric* index coding problem

$$(j | j - U, j - U + 1, \dots, j - 1, j + 1, \dots, j + D)$$

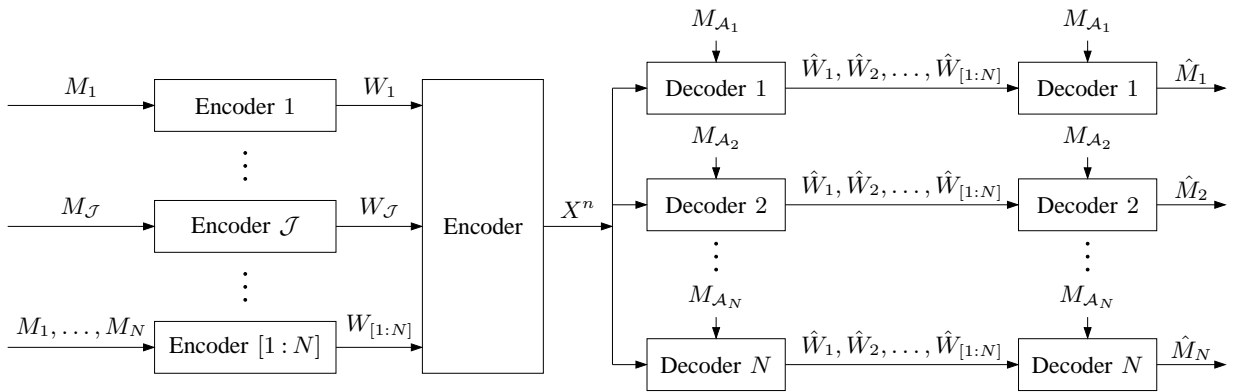

Fig. 6. Composite coding scheme.

for $j \in [1 : N]$, where all message indices are understood modulo N . For instance, the 5-message problem in Example 1 is a special case of this problem with $N = 5$ and $D = U = 1$. We assume without loss of generality that $0 \leq U \leq D \leq N - U - 1$. Let $S_{\mathcal{J}} = 1/(N - (D - U))$ if \mathcal{J} is of the form $[k : k + U]$, and let $S_{\mathcal{J}} = 0$ otherwise. Since receiver $j \in [1 : N]$ has M_{j+1}, \dots, M_{j+D} as side information, it already knows the $D - U$ composite indices $W_{[j+1:j+1+U]}, \dots, W_{[j+D-U:j+D]}$. Thus, there are only $N - (D - U)$ composite indices that need to be recovered from x^n , which is feasible since $\sum_{\mathcal{J}: \mathcal{J} \not\subseteq \mathcal{A}_j} S_{\mathcal{J}} = 1$. Now receiver j can recover M_j from the composite indices $W_{[j-U:j]}, \dots, W_{[j:j+U]}$, provided that

$$R_j < S_{[j-U:j]} + \dots + S_{[j:j+U]}.$$

Hence, the symmetric rate of $(U + 1)/(N - D + U)$ is achievable. In [17] it is shown that this symmetric rate is in fact optimal, which can be also verified directly by the outer bound in Theorem 1. For $N = 6, U = 1$, and $D = 2$, that is,

$$(1|2, 3, 6), (2|1, 3, 4), (3|2, 4, 5), \\ (4|3, 5, 6), (5|4, 6, 1), (6|5, 1, 2),$$

the symmetric rate of $2/5$ is optimal. In fact, simplifying Theorems 1 and 2 yields the capacity region that consists of the rate sextuples (R_1, \dots, R_6) such that

$$R_j + R_{j+2} \leq 1, \quad j \in [1 : 6], \\ R_j + R_{j+3} \leq 1, \quad j \in [1 : 6], \\ R_j + R_{j+1} + R_{j+2} + R_{j+3} + R_{j+4} \leq 2, \quad j \in [1 : 6].$$

In particular, this region is achievable by using composite indices $W_1, W_2, W_3, W_4, W_5, W_6, W_{1,2}, W_{2,3}, W_{3,4}, W_{4,5}, W_{5,6}$, and $W_{1,6}$.

VI. CONCLUDING REMARKS

Based on a first principle in Shannon's random coding, this paper has established the composite-coding inner bound on the general index coding problem. This inner bound is simple, easy to compute, yet is tight for all index coding problems of up to five messages as well as many existing examples. In a sense, random coding is a "jackknife" rather than a "hammer."

The polymatroidal structure of the composite-coding inner bound and the submodularity of the outer bound suggest a deeper connection rooted in matroid theory [20], [28]. In addition to evaluating the inner and outer bounds for more examples (there are 1540944 nonisomorphic six-message index coding problems), future studies will focus on analyzing the algebraic structures of these bounds to investigate what lies in the path to establishing the capacity region of a general index coding problem.

REFERENCES

[1] M. Langberg and M. Effros, "Network coding: Is zero error always possible?" in *Proc. 49th Ann. Allerton Conf. Comm. Control Comput.*, Monticello, IL, Sep. 2011, pp. 1478–1485.
[2] R. Ahlswede, N. Cai, S.-Y. R. Li, and R. W. Yeung, "Network information flow," *IEEE Trans. Inf. Theory*, vol. 46, no. 4, pp. 1204–1216, 2000.

[3] Y. Birk and T. Kol, "Informed-source coding-on-demand (ISCOD) over broadcast channels," in *Proc. 17th Ann. IEEE Int. Conf. Comput. Commun. (INFOCOM)*, San Francisco, CA, Mar. 1998, pp. 1257–1264.
[4] N. Alon, E. Lubetzky, U. Stav, A. Weinstein, and A. Hassidim, "Broadcasting with side information," in *49th Ann. IEEE Symp. Found. Comput. Sci.*, Philadelphia, PA, Oct. 2008, pp. 823–832.
[5] Y. Wu, J. Padhye, R. Chandra, V. Padmanabhan, and P. A. Chou, "The local mixing problem," in *Proc. UCSD Inf. Theory Appl. Workshop*, La Jolla, CA, 2006.
[6] E. Lubetzky and U. Stav, "Nonlinear index coding outperforming the linear optimum," *IEEE Trans. Inf. Theory*, vol. 55, no. 8, pp. 3544–3551, Aug. 2009.
[7] S. El Rouayheb, A. Sprintson, and C. Georghiades, "On the index coding problem and its relation to network coding and matroid theory," *IEEE Trans. Inf. Theory*, vol. 56, no. 7, pp. 3187–3195, Jul. 2010.
[8] Z. Bar-Yossef, Y. Birk, T. S. Jayram, and T. Kol, "Index coding with side information," *IEEE Trans. Inf. Theory*, vol. 57, no. 3, pp. 1479–1494, Mar. 2011.
[9] Y. Berger and M. Langberg, "Index coding with outerplanar side information," in *Proc. IEEE Int. Symp. Inf. Theory*, Saint Petersburg, Russia, Aug. 2011, pp. 806–810.
[10] A. Blasiak, R. Kleinberg, and E. Lubetzky, "Lexicographic products and the power of non-linear network coding," in *52nd Ann. IEEE Symp. Found. Comput. Sci.*, Palm Springs, CA, Oct. 2011, pp. 609–618.
[11] —, "Index coding via linear programming," 2011. [Online]. Available: <http://arxiv.org/abs/1004.1379>
[12] S. H. Dau, V. Skachek, and Y. M. Chee, "Optimal index codes with near-extreme rates," in *Proc. IEEE Int. Symp. Inf. Theory*, Cambridge, MA, Jul. 2012, pp. 2241–2245.
[13] M. Effros, S. El Rouayheb, and M. Langberg, "An equivalence between network coding and index coding," 2012. [Online]. Available: <http://arxiv.org/abs/1211.6660>
[14] I. Haviv and M. Langberg, "On linear index coding for random graphs," in *Proc. IEEE Int. Symp. Inf. Theory*, Cambridge, MA, Jul. 2012, pp. 2231–2235.
[15] A. Tehrani, A. G. Dimakis, and M. Neely, "Bipartite index coding," in *Proc. IEEE Int. Symp. Inf. Theory*, Cambridge, MA, Jul. 2012, pp. 2246–2250.
[16] K. Shanmugam, A. G. Dimakis, and M. Langberg, "Local graph coloring and index coding," 2013. [Online]. Available: <http://arxiv.org/abs/1301.5359>
[17] H. Maleki, V. R. Cadambe, and S. A. Jafar, "Index coding: An interference alignment perspective," in *Proc. IEEE Int. Symp. Inf. Theory*, Cambridge, MA, Jul. 2012, pp. 2236–2240.
[18] V. R. Cadambe and S. A. Jafar, "Interference alignment and degrees of freedom of the K -user interference channel," *IEEE Trans. Inf. Theory*, vol. 54, no. 8, pp. 3425–3441, Aug. 2008.
[19] A. H. Maslow, *The Psychology of Science: A Reconnaissance*. New York: Harper & Row, 1966.
[20] R. Dougherty, C. Freiling, and K. Zeger, "Network coding and matroid theory," *Proc. IEEE*, vol. 99, no. 3, pp. 388–405, Mar. 2011.
[21] H. Sun and S. A. Jafar, "Index coding capacity: How far can one go with only Shannon inequalities?" 2013. [Online]. Available: <http://arxiv.org/abs/1303.7000>
[22] H.-F. Chong, M. Motani, H. K. Garg, and H. El Gamal, "On the Han-Kobayashi region for the interference channel," *IEEE Trans. Inf. Theory*, vol. 54, no. 7, pp. 3188–3195, Jul. 2008.
[23] A. El Gamal and Y.-H. Kim, *Network Information Theory*. Cambridge: Cambridge University Press, 2011.
[24] N. J. A. Sloane, "Sequence A000273: Number of directed graphs (or digraphs) with n nodes," in *The On-Line Encyclopedia of Integer Sequences*, 2013, published electronically at <http://oeis.org/A000273/>.
[25] T. S. Han, "The capacity region of general multiple-access channel with certain correlated sources," *Inf. Control*, vol. 40, no. 1, pp. 37–60, 1979.
[26] B. Bandemer, A. El Gamal, and Y.-H. Kim, "Simultaneous nonunique decoding is rate-optimal," in *Proc. 50th Ann. Allerton Conf. Comm. Control Comput.*, Monticello, IL, Oct. 2012.
[27] M. Terzer, "Large scale methods to enumerate extreme rays and elementary modes," Ph.D. dissertation, Swiss Federal Institute of Technology (ETH), Zurich, 2009.
[28] J. G. Oxley, *Matroid Theory*. Oxford: Oxford University Press, 2006.