

Disjoint compatibility graph of non-crossing matchings of points in convex position

Oswin Aichholzer* Andrei Asinowski† Tillmann Miltzow‡

Monday 24th March, 2014

Abstract

Let X_{2k} be a set of $2k$ labeled points in convex position in the plane. We consider geometric non-intersecting straight-line perfect matchings of X_{2k} . Two such matchings, M and M' , are *disjoint compatible* if they do not have common edges, and no edge of M crosses an edge of M' . Denote by \mathbf{DCM}_k the graph whose vertices correspond to such matchings, and two vertices are adjacent if and only if the corresponding matchings are disjoint compatible. We show that for each $k \geq 9$, the connected components of \mathbf{DCM}_k form exactly three isomorphism classes – namely, there is a certain number of isomorphic *small* components, a certain number of isomorphic *medium* components, and one *big* component. The number and the structure of small and medium components is determined precisely.

Keywords: Planar straight-line graphs, disjoint compatible matchings, reconfiguration graph, non-crossing geometric drawings, non-crossing partitions, combinatorial enumeration.

1 Introduction

1.1 Basic definitions and main results

Let k be a natural number, and let X_{2k} be a set of $2k$ points in convex position in the plane, labeled circularly (say, clockwise) by P_1, P_2, \dots, P_{2k} (in figures, we label them just by $1, 2, \dots, 2k$). We consider geometric **perfect** matchings of X_{2k} realized by **non-crossing straight segments**. Throughout the paper, the expression “non-crossing matching”, or just the word “matching”, will only refer to matchings of this kind, and to their combinatorial and topological generalizations that will be defined below (unless specified otherwise). The *size* of such a matching is k , the number of edges. It is well-known that the number of matchings of X_{2k} is the k th Catalan number $C_k = \frac{1}{k+1} \binom{2k}{k}$ [25, A000108]. Three examples of matchings of size 8 are shown in Figure 1.

Two matchings M and M' of X_{2k} are *disjoint compatible* if they do not have common edges (*disjoint*), and no edge of M crosses an edge of M' (*compatible*). In Figure 1, the matchings M_a

*Institute for Software Technology, Technische Universität Graz. Inffeldgasse 16b/II, A-8010 Graz, Austria. E-mail address oaich@ist.tugraz.at.

†Institute of Computer Science, Freie Universität Berlin. Takustraße 9, 14195 Berlin, Germany. E-mail address asinowski@mi.fu-berlin.de.

‡Institute of Computer Science, Freie Universität Berlin. Takustraße 9, 14195 Berlin, Germany. E-mail address miltzow@mi.fu-berlin.de.

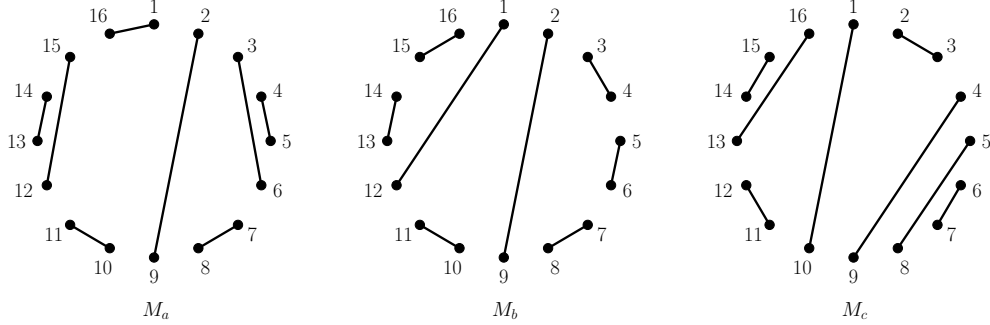

Figure 1: Three examples of matchings of size 8. M_b and M_c are disjoint compatible.

and M_b are not disjoint (P_2P_9 is a common edge); the matchings M_a and M_c are disjoint but not compatible (P_3P_6 of M_a and P_4P_9 of M_c cross each other); the matchings M_b and M_c are disjoint compatible.

The *disjoint compatibility graph* of matchings of size k is the graph whose vertices correspond to all such matchings of X_{2k} , and two vertices are adjacent if and only if the corresponding matchings are disjoint compatible. This graph will be denoted by \mathbf{DCM}_k . The graph \mathbf{DCM}_4 is shown in Figure 2. It is clear that, while we consider point sets in convex position, the graph \mathbf{DCM}_k does not depend on a specific set X_{2k} . Occasionally we shall adopt the terminology from graph theory for the matchings and say, for example, “matching M has degree d ”, “two matchings, M and N are connected” to mean “the vertex corresponding to M in \mathbf{DCM}_k has degree d ”, “the vertices corresponding to M and N in \mathbf{DCM}_k are connected”, etc. In particular, “ M' is adjacent to M ” and “ M' is a neighbor of M ” are synonyms of “ M' is disjoint compatible to M ”.

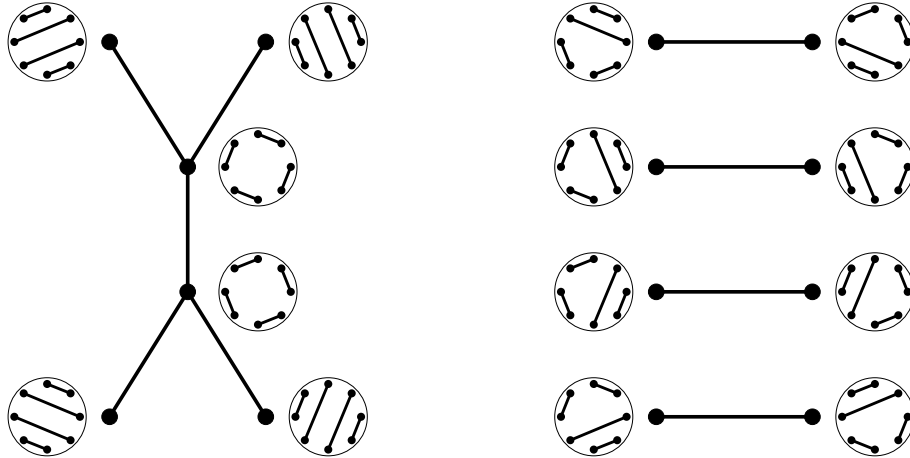

Figure 2: The graph \mathbf{DCM}_4 .

In this paper we study the graphs \mathbf{DCM}_k , mainly aiming for a description of their connected components from the point of view of their structure, order (that is, the number of vertices), and isomorphism classes. Our main results are the following theorems.

Theorem 1. *For each $k \geq 9$, the connected components of \mathbf{DCM}_k form exactly three isomorphism classes. Specifically, there are several isomorphic components of the smallest order, several isomorphic components of the medium order, and one component of the biggest order.*

In accordance to the orders, we call the components *small*, *medium* and *big*. The components of \mathbf{DCM}_k follow different regularities for odd and for even values of k , as specified in the next two theorems. In fact, some of these regularities also hold for smaller values of k , and thus we extend this notation for all values of k . Namely, the components of the smallest order are called *small*; the components of the next order are called *medium*; all other components are called *big*. It was found by direct inspection and by a computer program that for $1 \leq k \leq 8$ the number of isomorphism classes of the components of \mathbf{DCM}_k is as follows:

k	1	2	3	4	5	6	7	8
Number of isomorphism classes of the components of \mathbf{DCM}_k	1	1	2	2	3	3	4	4

However, as stated in Theorem 1, for all $k \geq 9$, \mathbf{DCM}_k has components of exactly three kinds: several small components, several medium components, and one big component.

Throughout the paper, we denote $\ell = \lceil \frac{k}{2} \rceil$.

Theorem 2. *Let k be an odd number, $\ell = \lceil \frac{k}{2} \rceil$.*

1. *The small components of \mathbf{DCM}_k are isolated vertices.
The number of such components is $\frac{1}{\ell} \binom{4\ell-2}{\ell-1}$.*
2. *For $k \geq 3$, the medium components of \mathbf{DCM}_k are stars of order ℓ (that is, $K_{1,\ell-1}$).
For $k \geq 5$, the number of such components is $(2\ell - 1) \cdot 2^{\ell-3}$.*

Theorem 3. *Let k be an even number, $\ell = \lceil \frac{k}{2} \rceil$.*

1. *The small components of \mathbf{DCM}_k are pairs (that is, components of order 2).
The number of such components is $\ell \cdot 2^{\ell-1}$.*
2. *For $k \geq 4$, the medium components of \mathbf{DCM}_k are of order $6\ell - 6$.¹
For $k \geq 6$, the number of such components is $\ell \cdot 2^{\ell-2}$.*

The enumerational results from these theorems, and exceptional values observed for small values of k , are summarized in Tables 1 and 2. As mentioned above, for $k = 7$ and for $k = 8$ two big components are of different order.

As stated in Theorem 1, for $k \geq 9$ there is only one big component. Thus, its order is the number of vertices that do not belong to small and medium components. In Proposition 39 we will show that the order of the big component is indeed larger than that of medium or small components.

¹ The structure of the medium components for even k will be described below, in Corollary 34.

k	1	3	5	7	9	11	...	General formula
$\ell = \frac{k+1}{2}$	1	2	3	4	5	6	...	
Small components: order	1	1	1	1	1	1	...	1
Small components: number	1	3	15	91	612	4389	...	$\frac{1}{\ell} \binom{4\ell-2}{\ell-1}$
Medium components: order	–	2	3	4	5	6	...	ℓ (for $\ell \geq 2$)
Medium components: number	–	1	5	14	36	88	...	$(2\ell - 1) \cdot 2^{\ell-3}$ (for $\ell \geq 3$)

Table 1: The summary of enumerational results for odd k (Theorem 2).

k	2	4	6	8	10	12	...	General formula
$\ell = \frac{k}{2}$	1	2	3	4	5	6	...	
Small components: order	2	2	2	2	2	2	...	2
Small components: number	1	4	12	32	80	192	...	$\ell \cdot 2^{\ell-1}$
Medium components: order	–	6	12	18	24	30	...	$6\ell - 6$ (for $\ell \geq 2$)
Medium components: number	–	1	6	16	40	96	...	$\ell \cdot 2^{\ell-2}$ (for $\ell \geq 3$)

Table 2: The summary of enumerational results for even k (Theorem 3).

1.2 Background and motivation

The general notion of disjoint compatibility graphs was defined by Aichholzer et al. [1] for sets of $2k$ points in general (not necessarily convex) position. While they showed that for odd k there exist isolated matchings, they posed the *Disjoint Compatible Matching Conjecture* for even k : For every non-crossing matching of even size, there exists a disjoint compatible non-crossing matching. This conjecture was recently answered in the positive by Ishaque et al. [19]. In that paper it was stated that for even k “it remains an open problem whether [the disjoint compatibility graph] is always connected.” It follows from our results that for sets of $2k$ points in convex position, \mathbf{DCM}_k is **always** disconnected, with the exception of $k = 1$ and 2.

Both concepts, disjointness and compatibility, can be found in generalized form for various geometric structures. For example, two triangulations are compatible if one can be obtained from the other by removing an edge in a convex quadrilateral and replacing it by the other diagonal. This operation is called a flip and it is well known that in that way any triangulation of the given set of n points can be obtained from any other triangulation of the same set with at most $O(n^2)$ flips, see e. g. [18]. Similar results exist, for example, for spanning trees [2] and between matchings and other geometric graphs [4, 17].

It is convenient to describe such results in terms of *reconfiguration graphs*, whose vertices correspond to all configurations under discussion, two vertices being adjacent when the corresponding configurations can be obtained from each other by certain operation (“reconfiguration”). In these terms, the above mentioned result about flips in triangulations can be stated as follows: the flip graph of triangulations is connected with diameter $O(n^2)$.

Some kinds of reconfiguration graphs of non-crossing matchings were studied as well. Herando et al. [16] studied graphs of non-crossing perfect matchings of $2k$ points in **convex** position with respect to reconfiguration of the kind $M' = M - (a, b) - (c, d) + (b, c) + (d, a)$. In particular, they proved that such a graph is $(k - 1)$ -connected and has diameter $k - 1$, and it is bipartite for every k . Aichholzer et al. [1] considered graphs of non-crossing perfect matchings of $2k$ points in **general** position, where the matchings are adjacent if and only if they are compatible (but not necessarily disjoint). They showed that in such a graph there always exists a path of length at most $O(\log k)$ between any two matchings. Hence, such graphs are connected with diameter $O(\log k)$; lower bound examples with diameter $\Omega(\log k / \log \log k)$ were found by Razen [21, Section 4].

In general, the number of non-crossing matchings of a point set depends on its order type. In contrast to the case of point sets in convex position, for general point sets no exact bounds are known. Sharir and Welzl [23] proved that any set of n points has $O(10.05^n)$ non-crossing matchings. García et al. [15] showed that the number of non-crossing matchings is minimal when the points are in convex position (then, as mentioned above, the number of matchings is $C_{n/2} = \Theta^*(2^n)$), and constructed a family of examples with $\Theta^*(3^n)$ matchings. In these papers, bounds for similar problems concerning other geometric non-crossing structures (triangulations, spanning trees, etc.) are also found.

A generalization for matchings are *bichromatic matchings*. There the point set consists of k red and k blue points, and an edge always connects a red point to a blue point. It has recently been shown by Aloupis et al. [5] that the graph of compatible (but not necessarily disjoint) bichromatic matchings is connected. Moreover, the diameter of this graph is $O(k)$, see [3]. On the other hand, certain bichromatic point sets have only one bichromatic matching: such sets were characterized in [6].

From the combinatorial point of view, non-crossing matchings of points in convex position are identical to so called *pattern links*. Pattern links of size k form a basis for Temperley-Lieb algebra $TL_k(\delta)$ that was first defined in [26], and has numerous applications in mathematical physics, knot theory, etc. Pattern links also have a close relation with alternating sign matrices (ASMs), fully packed loops (FPLs), and other combinatorial structures. For more information see the survey article by Propp [20]. Di Francesco et al. [13] constructed a bijection between FPLs with a link pattern consisting of three nested sets of sizes a , b and c and the plane partitions in a box of size $a \times b \times c$. Wieland [27] proved that the distribution of link patterns corresponding to FPLs is invariant under dihedral relabeling. A connection between the distribution of link patterns of FPLs and ground-state vector of $O(1)$ loop model from statistical mechanics was intensively studied in the last years: see, for example, a proof of Razumov-Stroganov conjecture [22] (which can be also expressed in terms of reconfiguration) by Cantini and Sportiello [9].

Thus, our contribution is twofold. First, from the combinatorial point of view, we have structural results that provide a new insight into combinatorics of non-crossing partitions. Second, our work is a contribution to the study of straight-line graph drawings. While it applies only to matchings of points in convex position, certain observations may be carried over or generalized for general sets of points, and, thus, they could be possibly useful for the study of disjoint compatibility of geometric matchings in general.

1.3 Outline of the paper.

The paper is organized as follows. In Section 2 we introduce notion necessary for the proofs of the main theorems, and prove some preliminary results. One important notion there will be that of *block*: two edges that connect four consecutive points of X_{2k} , the first with the fourth, and the second with the third. In particular, it will be observed that if a matching M has a block, then in any matching disjoint compatible to M the points of the block can be reconnected in a unique way. Thus, presence of blocks puts restrictions on potential matchings disjoint compatible to M .

In Section 3 we describe certain kinds of matchings and show that they belong to components of the smallest possible order (1 or 2, depending on the parity of k). In Section 4, we describe other kinds of matchings, and prove that, for fixed k , all the connected components that contain such matchings are isomorphic. Enumerational results from these sections fit the rows of Tables 1 and 2 that correspond to medium components. Finally, in Section 5, we prove that for $k \geq 9$ all the matchings that do not belong to either of the kinds from Sections 3 and 4, form one connected component of big order (essentially, we prove that all such matchings are connected by a path to so called *rings*). In particular, this implies that no other orders exist, and that all the small and medium components are, indeed, described in Sections 3 and 4. Thus, this accomplishes the proof of Theorems 1, 2 and 3. In the concluding Section 6, we showing more enumerational results related to **DCM**, briefly discuss the case of “almost perfect” matchings of sets that have odd number of points, and suggest several problems for future research.

2 Further definitions and basic results

2.1 Flipping

If an edge of a matching connects two consecutive points of X_{2k} , it is a *boundary edge*, otherwise it is a *diagonal edge*. (We regard X_{2k} as a cyclic structure. Thus, the points P_{2k} and P_1 are also considered consecutive. Moreover, the arithmetic of the labels will be modulo $2k$. Yet we write P_{2k} rather than P_0 .) In the matching M_a in Figure 3, the edges P_3P_8 and $P_{13}P_{16}$ are diagonal edges, and all other edges are boundary edges. A pair of consecutive points not connected by an edge is a *skip*. For each $k \geq 2$ there are two matchings with only boundary edges, which we call *rings*. Notice that the two rings are disjoint compatible to each other.

The definition of disjoint compatible matchings can be rephrased as follows.

Observation 4. *Let M and M' be matchings of X_{2k} . M and M' are disjoint compatible if and only if $M \cup M'$ is a union of pairwise disjoint cycles that consist alternately of edges of M and M' .*

See Figure 3 for an example.

Let M be a matching of X_{2k} , and let Y be a subset of X_{2k} of size $2m$ ($2 \leq m \leq k$) whose members are labeled cyclically by Q_1, Q_2, \dots, Q_{2m} . (In other words, $Q_a = P_{i_a}$, and $\{i_1, i_2, \dots, i_{2m}\}$ is a subset of $\{1, 2, \dots, 2k\}$ with the induced cyclic order.) If $N = \{Q_1Q_2, Q_3Q_4, Q_5Q_6, \dots, Q_{2m-3}Q_{2m-2}, Q_{2m-1}Q_{2m}\}$ is a subset of M , and the convex hull of Y does not intersect any other edge of M , we say that N is a *flippable set*. Replacing the set N by the set $N' = \{Q_2Q_3, Q_4Q_5, Q_6Q_7, \dots, Q_{2m-2}Q_{2m-1}, Q_{2m}Q_1\}$ is a *flip* of N .

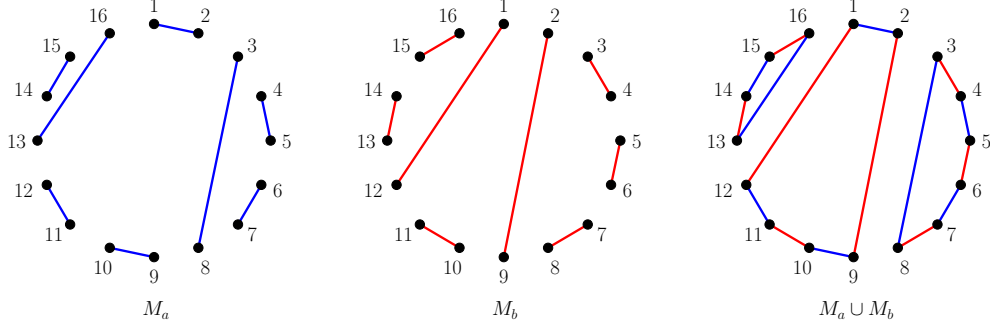

Figure 3: The union of disjoint compatible matchings is a union of disjoint alternating cycles.

Proposition 5. *Let M and M' be non-crossing matchings of X_{2k} . M and M' are disjoint compatible if and only if there is a (uniquely determined) partition of M into flippable sets with pairwise disjoint convex hulls so that M' is obtained from M by flipping them.*

Proof. [\Leftarrow] In such a case, $M \cup M'$ is a union of pairwise disjoint cycles as in Observation 4. [\Rightarrow] Taking the edges of M that belong to a cycle as in Observation 4, we obtain a flippable set. Since these cycles are connected components of $M \cup M'$, the partition of M into flippable sets is uniquely determined by M and M' . Since the cycles are disjoint, these flippable sets have disjoint convex hulls. \square

A partition as in Proposition 5 will be called a *flippable partition*. Notice that a flippable set can not always be extended to a flippable partition. For example, the set $T = \{P_1P_2, P_3P_8, P_{13}P_{16}\}$ from the matching M_a in Figure 3 is a flippable set, but there is no flippable partition that contains this set because there is no flippable set that contains $\{P_{14}P_{15}\}$ and doesn't cross T .

2.2 Merging and splitting of matchings

In some cases we need to split a matching into two submatchings, or to merge two matchings into one matching. Let L and N be non-empty disjoint subsets (submatchings) of a matching M so that their union is M , and so that L can be separated from N by a line. In such a case we write $M = L + N$, or $N = M - L$, and say that $L + N$ is a *decomposition* of M . If we want to treat L and N as matchings of respective sets of points, we need to indicate how the labeling of M is split into, or merged from the respective labelings of L and N . We formalize the merging of two matchings in the following way. Let L be a matching of $2r$ points $\{R_1, R_2, \dots, R_{2r}\}$, and let N be a matching of $2s$ points $\{S_1, S_2, \dots, S_{2s}\}$. A matching M obtained by *insertion of N into L between the points R_a and R_{a+1}* is the matching of $2k = 2r + 2s$ points P_1, P_2, \dots, P_{2k} obtained by relabeling (and putting in convex position) from $R_1, R_2, \dots, R_a, S_1, S_2, \dots, S_{2s}, R_{a+1}, R_{a+2}, \dots, R_{2r}$ (in this order), such that P_iP_j is an edge if and only if the corresponding points are connected in L or in N . If N is inserted into L between R_{2r} and R_1 , we have $2s + 1$ possibilities to choose the point corresponding to P_1 : R_1 or either of the points S_i . A similar procedure can be described for splitting a matching (we omit the details).

In some cases specifying the labeling upon merging or splitting will not be essential. For example, in some proofs we split a matching M into two submatchings L and N , modify both parts, and then merge them again. In such a case we only need to make sure that when the

parts are merged, their vertices are labeled in the same way as before the splitting. Assuming this convention, we mention the following obvious fact.

Observation 6. *Let M be a matching, and suppose that $L + N$ is its decomposition. If L' is a matching disjoint compatible to L , and N' is a matching disjoint compatible to N , then $L' + N'$ is disjoint compatible to M .*

If we start with a matching M_0 , and perform insertion several times (each time the inserted matching, the place of insertion, and, if needed, the labeling are specified), obtaining thus a sequence of matchings M_1, M_2, \dots , then for each edge e of M_0 , each of the members of this sequence has an edge corresponding to e in the obvious sense.

2.3 Combinatorial and topological matchings

For the sets of points in convex position, the notions of non-crossing matchings and that of disjoint compatible matchings are in fact purely combinatorial, since being two edges crossing or non-crossing is completely determined by the labels of their endpoints. Indeed, let X_{2k} be just the set $\{1, 2, \dots, 2k\}$. Two disjoint pairs of members of X_{2k} , $\{a_1, a_2\}$ and $\{b_1, b_2\}$, are *crossing* if, when ordered with respect to the usual cyclic order of X_{2k} , they form a sequence of the form $abab$. A *combinatorial non-crossing matching* of X_{2k} is its partition M into k disjoint non-crossing pairs. Two such matchings, M and M' , are disjoint compatible if no pair belongs to them both, and no pair from M crosses a pair from M' .

Combinatorial non-crossing matchings can be represented not only by straight-line (“geometric”) drawings, but also by more general “topological drawings”, as follows. Let Γ be a closed Jordan curve, and let $X_{2k} = \{P_1, \dots, P_{2k}\}$ be a set of points that lie (say, clockwise) on Γ in this cyclic order. Denote by $\mathbf{O}(\Gamma)$ the interior, that is, the region bounded by Γ . A *topological non-crossing matching* is a set of k non-intersecting Jordan curves that connect pairs of these points, and whose interior lies in $\mathbf{O}(\Gamma)$. Since $\mathbf{O}(\Gamma)$ is homeomorphic to an open disc (by the Jordan-Schoenflies theorem), each topological non-crossing matching can be continuously transformed into a geometric non-crossing matching. Notice, however, that (in contrast to geometric matchings) two topological matchings (on the same X_{2k} and Γ) that correspond to disjoint compatible combinatorial matchings might have crossing arcs.

In what follows, by a (non-crossing) matching we usually mean either a combinatorial non-crossing matching as described above, or any of its topological or straight-line representations. When a specific kind of drawing should be considered, we will mention it explicitly.

2.4 The map and the dual tree

Consider a topological non-crossing matching M of size k . Then the union of Γ and the members of M form a planar map in $\mathbf{O}(\Gamma)$. This map has $k + 1$ faces. The boundary of each face consists of one or several pieces of Γ and one or several edges of M . Each edge belongs to exactly two faces. A face that has more than one edge will be called an *inner face*; a face that has exactly one edge (which is then necessarily a boundary edge) will be called a *boundary face*. Notice that any flippable set is a subset of the set of edges that belong to one (inner) face.

Consider the dual graph of this map, regarded as a combinatorial embedding (that is, for each vertex v the cyclic order $\phi(v)$ of edges incident to v is specified) with labeled *edge sides*. This graph T is a tree: it is easy to see that T is connected and acyclic, as removal of any edge of T disconnects

it. It will be called the *dual tree* of M , and denoted by $D(M)$. Since each edge of $D(M)$ crosses exactly one edge of M , the points of X_{2k} correspond to the edge sides of $D(M)$ in a natural way; therefore, we use the indices of the points as labels of the edge sides. The boundary edges of M correspond to the edges of $D(M)$ incident to leaves, and, thus, there is also a clear correspondence of the boundary edges of M to the leaves of $D(M)$. The skips of M correspond to the *wedges* – pairs of edges incident to a vertex v , consecutive in $\phi(v)$ (geometrically, in case of straight-line drawing, the wedges are angles formed by edges incident to the same vertex v , with the center in v). In Figure 4(a, b), a matching M (black) and its dual tree $D(M)$ (blue) are shown.

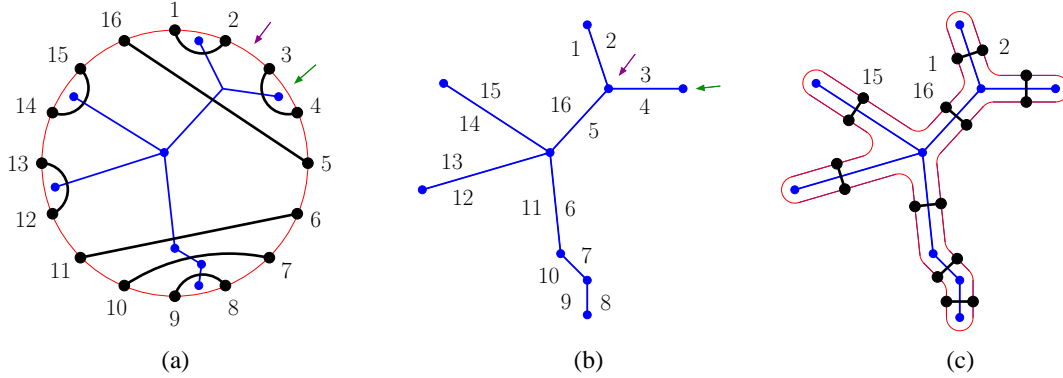

Figure 4: (a) A matching. (b) Its dual tree. (c) Reconstructing the matching from its dual tree.

Combinatorial embeddings of trees with $k + 1$ vertices and one marked edge side are in bijection with matchings of size k . Notice that one marked edge side (we use the label 1 as the mark) in such an embedding T determines a labeling of edge sides of T by $\{1, 2, \dots, 2k\}$ that agrees with a cyclic ordering of edge sides determined by a *clockwise double edge traversal*.² Figure 4(c) shows how, given such a combinatorial embedding of a tree T , one can construct the matching M such that $D(M) = T$. First, we take a drawing of T (for example, a straight-line drawing – it is well-known that such a drawing always exists) and slightly inflate its edges. The boundary of the obtained shape is a closed Jordan curve Γ , it can be seen as a route of the double edge traversal. For each edge of T , we put a point on Γ on each of its sides, and connect such pairs by arcs. As explained above, the edge sides of T are labeled by $\{1, 2, \dots, 2k\}$. The point that lies on the edge side i will be labeled by P_i . The set of arcs is now a non-crossing matching whose dual tree is T . This topological matching can be converted now into a straight-line matching of points in convex position as explained above. Without a marked edge side, a combinatorial embedding determines a class of *rotationally equivalent* matchings, that is, matchings that can be obtained from each other by a cyclic relabeling of vertices. We summarize our observations as follows.

Observation 7.

1. The correspondence $M \mapsto D(M)$ is a bijection between combinatorial embeddings of trees with $k + 1$ vertices and one marked edge side and non-crossing matchings of size k .
2. Two non-crossing matchings, M_1 and M_2 , have the same non-labeled dual tree if and only if they are rotationally equivalent.

²In a double edge traversal, each edge is visited twice: once for each direction. After visiting an edge $e = v_1v_2$ from v_1 to v_2 , we visit the edge v_2v_3 , the successor of e in $\phi(v_2)$, from v_2 to v_3 .

2.5 Blocks and antiblocks

Definition. Let M be a matching of X_{2k} , $k \geq 2$.

1. A *block* is a pair of edges of M of the form $\{P_i P_{i+3}, P_{i+1} P_{i+2}\}$.
2. An *antiblock* is a pair of edges of M of the form $\{P_i P_{i+1}, P_{i+2} P_{i+3}\}$.
3. A *separated pair* is a block or an antiblock.

For example, in the matching M_a from Figure 3, $\{P_{13} P_{16}, P_{14} P_{15}\}$ is a block, and $\{P_4 P_5, P_6 P_7\}$ is an antiblock. If we have a separated pair on points $P_i, P_{i+1}, P_{i+2}, P_{i+3}$, then they will be called, respectively, the first, the second, the third, and the fourth points of the separated pair. For a block $K = \{P_i P_{i+3}, P_{i+1} P_{i+2}\}$, the edge $P_i P_{i+3}$ is the *outer*, and the edge $P_{i+1} P_{i+2}$ is the *inner* edge of K .³ For $k > 3$ two blocks in a matching are necessarily disjoint, while two antiblocks can share an edge. The block $\{P_i P_{i+3}, P_{i+1} P_{i+2}\}$ and the antiblock $\{P_i P_{i+1}, P_{i+2} P_{i+3}\}$ are *flips* of each other. The special role of blocks is due to the following observation.

Observation 8. *Let M and M' be two disjoint compatible matchings. If M has a block $\{P_i P_{i+3}, P_{i+1} P_{i+2}\}$, then M' has an antiblock $\{P_i P_{i+1}, P_{i+2} P_{i+3}\}$.*

Proof. Consider a flippable partition of M . The only flippable set of M that contains the edge $P_{i+1} P_{i+2}$ is the block $\{P_i P_{i+3}, P_{i+1} P_{i+2}\}$. Upon flipping, an antiblock on these points is obtained. \square

Given a matching M of size k , we can obtain a matching of size $k + 2$ by inserting a matching K of size 2. When essential, we can use the rule of relabeling vertices as explained in Section 2.2. However, instead of specifying a labeling of K , we say that we insert a block or an antiblock into M in accordance to the shape formed by the edges corresponding to K in $M + K$.

The definition of the dual tree and the correspondence between elements of M and $D(M)$ (explained before Observation 7) allow to identify elements of $D(M)$ that correspond to separated pairs.

Definition. Let T be a combinatorial embedding of a tree.

1. A *k-branch* in T is a path $v_1 v_2 \dots v_{k+1}$ of length k whose one end (v_{k+1}) is a leaf in T , and all the inner vertices (v_2, v_3, \dots, v_k) have degree 2. A *k-branch* will be given by the list of its vertices, starting from v_1 .
2. A *V-shape* in T is a path $v_1 v_2 v_3$ such that v_1 and v_3 are leaves in T , and the edge $v_2 v_3$ follows the edge $v_2 v_1$ in $\phi(v_2)$ (in other words, $v_1 v_2 v_3$ is a wedge). A *V-shape* will be given by the list of its vertices in this order, corresponding to the clockwise double edge traversal: $v_1 v_2 v_3$.

Observation 9. *Blocks in M correspond to 2-branches in $D(M)$. Antiblocks in M correspond to V-shapes in $D(M)$.*

³ A special case is $k = 2$. Consider $M = \{P_1 P_2, P_3 P_4\}$. The whole matching is both a block and an antiblock. For M as a block, P_2 or P_4 can be taken as the first point. For M as an antiblock, P_1 or P_3 can be taken as the first point. The case of $M = \{P_1 P_4, P_2 P_3\}$ is similar.

Suppose now that T is a combinatorial embedding of a tree, and we want to add a k -branch or a V-shape to T . The following convention will be adopted. We say that an embedding T' is obtained from T by attaching a k -branch $v_1v_2\dots v_{k+1}$ to vertex w of T in the wedge w_1ww_2 , if (1) $v_1 = w$, (2) the vertices v_2, \dots, v_{k+1} are vertices of T' but not of T , and (3) for w in T' we have $w_1w_1 \prec ww_2 \prec ww_2$ in $\phi(w)$. We say that an embedding T' is obtained from T by attaching a V-shape $v_1v_2v_3$ to vertex w of T in the wedge w_1ww_2 , if (1) $v_2 = w$, (2) the vertices v_1, v_3 are vertices of T' but not of T , and (3) for w in T' we have $w_1w_1 \prec ww_1 \prec ww_3 \prec ww_2$ in $\phi(w)$.

Observation 10. *Let M be a matching.*

Inserting a block (respectively, an antiblock) in M between the points P_i, P_{i+1} connected by an edge in M corresponds to attaching a 2-branch (respectively, a V-shape) to the leaf corresponding to this edge in $D(M)$.

Inserting a block (respectively, an antiblock) in M between the points P_i, P_{i+1} not connected in M corresponds to attaching a 2-branch (respectively, a V-shape) to the vertex in the wedge corresponding to the skip between P_i and P_{i+1} in $D(M)$.

See Figure 5: M is a matching of size 4; M_a and M_b are obtained from M by inserting a block and, respectively, an antiblock between P_2 and P_3 (not connected in M); M_c and M_d are obtained from M by inserting a block and, respectively, an antiblock between P_3 and P_4 (connected in M).

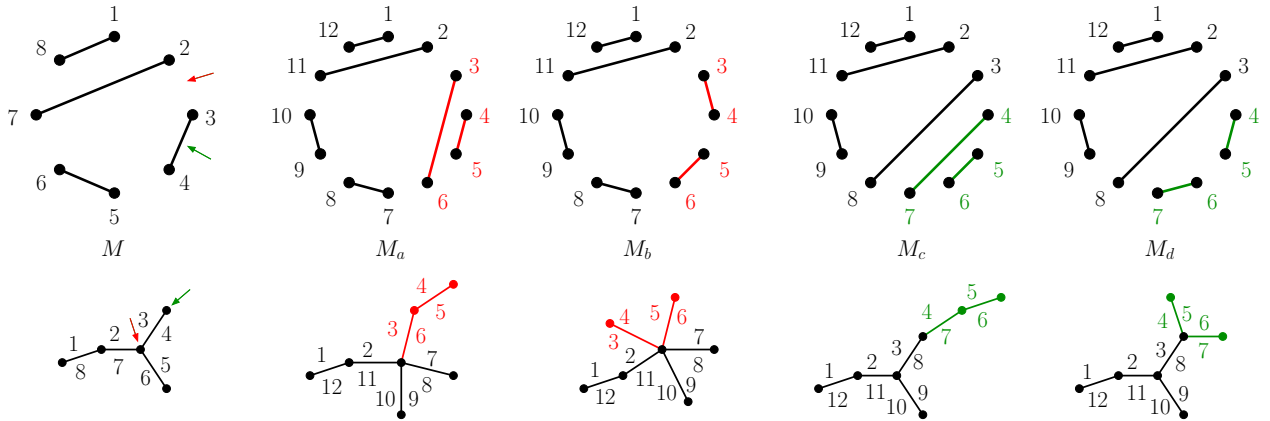

Figure 5: Illustration to Observation 10.

Proposition 11. *Let M be a matching of size $k \geq 4$. Then M has at least two disjoint separated pairs.*

Proof. If M is a ring, the statement is clear. Otherwise, $D(M)$ is not a star, and, thus, its diameter is at least 3. Let v_1 and v_2 be the leaves with the maximum distance in $D(M)$, and let u_1 and u_2 be the vertices adjacent to them (respectively). If $d(u_1) = 2$, we have a 2-branch in $D(M)$, and, therefore, a block in M . If $d(u_1) > 2$, we have a V-shape in $D(M)$, and, therefore, an antiblock in M . The same holds for u_2 . Since $u_1 \neq u_2$, these separated pairs are disjoint, unless the whole $D(M)$ is the path $v_1u_1u_2v_2$. But this situation is impossible since $k \geq 4$. \square

Proposition 12. *Let M be a matching of size k , and let $N = M + K$ where K is a block.⁴ Then the degree of N in \mathbf{DCM}_{k+2} is equal to the degree of M in \mathbf{DCM}_k .*

Proof. The mapping $M' \mapsto M' + K'$, where M' is a matching disjoint compatible to M , and K' is the antiblock that uses the same points as K , is a bijection between matchings disjoint compatible to M and matchings disjoint compatible to N . \square

Proposition 13. *Let M be a matching of size k , and let $N = M + K$ where K is a block or an antiblock. If M is connected (by a path) in \mathbf{DCM}_k to p matchings, then N is connected (by a path) in \mathbf{DCM}_{k+2} to at least p matchings.*

Proof. Consider the mapping $M' \mapsto M' + K'$, where M' is a matching connected by a path to M , $K' = K$ if $d(M, M')$ is even, and K' is the flip of K if $d(M, M')$ is odd. It follows by induction on the distance and by Observation 6 that for each M' , the matching $M' + K'$ is connected by a path to N . It is also clear that this mapping is an injection. \square

3 Small components and vertices of small degree

3.1 General discussion

A matching M is *isolated* if it is not disjoint compatible to any other matching of the same point set (in other words, it corresponds to an isolated vertex of \mathbf{DCM}_k). First we show that no isolated matchings of even size exists.⁵

Proposition 14. *If M is a matching of even size k , then there is at least one matching disjoint compatible to M .*

Proof. For $k = 2$, the statement is obvious. For $k \geq 4$: by Proposition 11, M has a separated pair K . Let $L = M - K$. By induction, there exists a matching L' disjoint compatible to L . Now, $L' + K'$, where K' is the flip of K , is disjoint compatible to M by Observation 6. \square

In Section 3.2 we shall prove that for any odd k there are isolated matchings of size k , and in Section 3.6 we shall prove that for any even k , \mathbf{DCM}_k has connected components of size 2.

First we derive certain situations in which a matching necessarily has at least one, or two, disjoint compatible matchings.

Proposition 15. *Let M be a matching of size $k \geq 2$.*

1. *If M has no blocks, then there are at least two matchings disjoint compatible with M .*
2. *If M has exactly one block, then there is at least one matching disjoint compatible with M .*

Proof. For $k = 2, 3$, we verify this directly (for $k = 2$ the statement holds in a trivial way). For $k \geq 4$, we prove the statement by induction (notice that the induction applies not to 1. and 2. separately, but rather to the whole statement).

⁴ Since the place where K was inserted is not specified, this means: N is some matching that can be obtained from M by adding a block.

⁵ As mentioned in the introduction, this claim also holds for matchings of points in general (not necessarily convex) position [19, Theorem 1]. However, since for the convex case the proof is very simple, we present it here for completeness.

1. Suppose that M has no blocks. If M is a ring, then the claim is clear. So, we assume that there is a diagonal edge $e = P_i P_j$. Let M_1 and M_2 be the submatchings of M on point sets $Y_1 = \{P_{i+1}, P_{i+2}, \dots, P_{j-1}\}$ and $Y_2 = \{P_{j+1}, P_{j+2}, \dots, P_{i-1}\}$ (respectively). Since M has no blocks, both these submatchings are of size at least 2.

Consider the submatching M_1 . If it has a block K , then its first point can be only one of the points P_{j-3}, P_{j-2} , and P_{j-1} , because otherwise K would be also a block of M . It follows that M_1 has at most one block. Therefore, it is not isolated by induction. Similarly, $\{e\} \cup M_2$ has at most one block (its first point can be only P_{i-1}), and therefore, it is also not isolated. Denote by M'_1 a matching disjoint compatible to M_1 , and by M''_2 a matching disjoint compatible to $\{e\} \cup M_2$. Then $M'_1 + M''_2$ is disjoint compatible to M .

Similarly, the submatchings $M_1 \cup \{e\}$ and M_2 are non-isolated, and $M''_1 + M'_2$, the merge of their respective disjoint compatible matchings, is disjoint compatible to M .

Thus we obtained two matchings, disjoint compatible to M . They are indeed distinct because in $M'_1 + M''_2$ the endpoints of e are connected to points from Y_2 , and in $M''_1 + M'_2$ to points of Y_1 .

2. Suppose that M has exactly one block K . Let $L = M - K$. Similarly to the reasoning from the previous paragraph, L has at most one block, and, thus, it is not isolated by induction. Therefore, M is also not isolated by Observation 6.

□

Remark. The statements of Proposition 15 cannot be strengthened as the examples in Figure 6 (for both even and odd k) show. The matching M_a has no blocks, and it has exactly two disjoint compatible matchings. The matching M_b has exactly one block, and it has exactly one disjoint compatible matching. In order to see that, notice that a disjoint compatible matching for M_a or for M_b is completely determined by deciding whether its antiblock(s) form a flippable set alone, or together with an adjacent (vertical) edge.



Figure 6: M_a has no block and exactly two disjoint compatible matchings. M_b has one block and exactly one disjoint compatible matching.

In the drawings in Figure 6, Γ is a rectangle, and all the edges of the matchings are either horizontal segments that lie on the lower or on the upper side, or vertical segments that connect these sides. Such a representation will be called a *strip drawing*. Strip drawings are very convenient for representation of certain kinds of matchings, and they will be used intensively in subsequent sections. Notice that the fact that horizontal segments lie *on* Γ is inconsistent with our definitions (in particular, that of the dual graph), but they can be easily adjusted. For example, we can treat this drawing as schematic and imagine that the horizontal segments are in fact slightly curved towards $\mathbf{O}(\Gamma)$.

3.2 Small components for odd k (Isolated Matchings)

In contrast to the even case, for each odd k there exist isolated matchings of size k . It is mentioned in [1] that the matchings rotationally equivalent to $M = \{P_1P_{2k}, P_2P_{2k-1}, \dots, P_kP_{k+1}\}$ are isolated for odd k . In this section we describe all isolated matchings (for the convex case). Figure 7 shows a few examples of isolated matchings – in fact, up to rotation, these are all isolated matchings of sizes 1 (a), 3 (b), 5 (c, d).

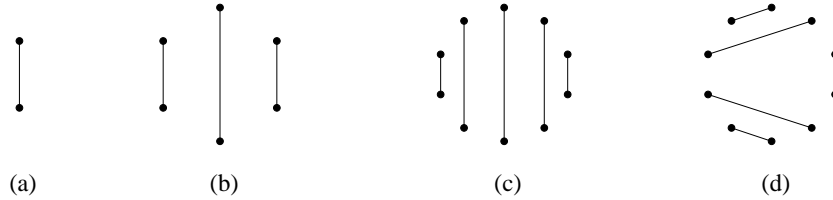

Figure 7: Examples of isolated matchings.

Definition. An *I-matching* is either a (unique) matching of size 1, or a matching of odd size $k \geq 3$ obtained from an I-matching of size $k - 2$ by inserting a block in any place.

Theorem 16. A matching of odd size k is isolated in \mathbf{DCM}_k if and only if it is an I-matching.

Proof. Let M be a matching of odd size k . For $k = 1$ the statement is clear. Assume $k \geq 3$.

If M has no blocks, then it is not isolated by Proposition 15 (1), and it is not an I-matching by definition.

If M has at least one block, the theorem follows from Proposition 12 which says that inserting a block does not change the degree. \square

We prove several facts about I-matchings to be used later.

Observation 17. An I-matching of size $k \geq 3$ has at least two blocks (which are disjoint for $k \geq 5$).

Proof. By Proposition 15, for $k > 1$, any matching with at most one block is not isolated. For $k \geq 4$, two blocks are always disjoint. \square

Proposition 18. If M is an I-matching, then it has no antiblocks.

Proof. The matching of size 1 clearly has no blocks. An insertion of a block into a matching without antiblocks never produces a matching with an antiblock. \square

We color the edges of I-matchings in the following way. Let M be an I-matching of size k , and let $e \in M$. Then e separates M into two (possibly empty) submatchings whose total size is $k - 1$. If both these submatchings are of even size, e will be colored red; if they are of odd size, e will be colored black. The edges of $D(M)$ will be colored correspondingly. See Figure 8. The following facts are obvious, or easily seen by induction.

Observation 19. Let M be an I-matching of size k .

1. The only edge of the matching of size 1 is red.

2. When a block K is inserted in M so that an I-matching $M + K$ is obtained, then the edges of $M + K$ corresponding to those of M , preserve their color; and the edges corresponding to those of K are colored as follows: the outer edge is black, and the inner edge is red.
3. The number of red edges is $\ell (= \lceil \frac{k}{2} \rceil)$, and the number of black edges is $\ell - 1$.
4. Each face of the dual map of M has exactly one red edge. Correspondingly, each vertex of $D(M)$ is incident to exactly one red edge.

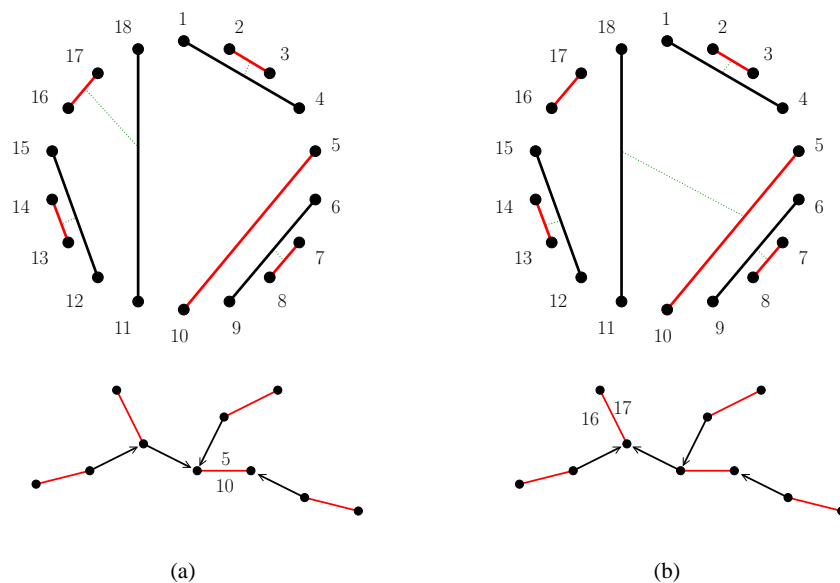

Figure 8: An I-matching and its dual graph. (a) The root is P_5P_{10} . (b) The root is $P_{16}P_{17}$.

According to the definition, in order to construct an I-matching M we start with a matching of size 1, and insert blocks recursively. The edge of M corresponding to the initial edge will be called the *root*. Pairs of edges corresponding to the members of a block inserted in some stage of the recursive construction, will be called *twins*. However, the same I-matching can be constructed in several ways, and therefore the root and the twins are not uniquely defined for M but rather depend on the specific construction (a sequence of insertions of blocks). Referring to a specific construction, we connect twins by green dotted lines (thus, the root is the only edge not connected in this way to any other edge). In the dual graph, we draw an arrow on the black edge which points to the point to which it is attached. See Figure 8(b) for an example: in the first drawing the root is P_5P_{10} , in the second drawing it is $P_{16}P_{17}$. See Figure 8(b) for an example: in the first drawing the root is P_5P_{10} , in the second drawing it is $P_{16}P_{17}$ (notice that the order of inserting the blocks can be also chosen in several ways).

Proposition 20. *Let M be an I-matching.*

1. For any red edge e of M , there exists a recursive construction of M such that e is the root.
2. For each choice of the root, the pairs of twins are determined uniquely.

Proof. For $k = 1$ the statements hold trivially. Assume $k \geq 3$. Let K be a block that does not contain e (existence of such a block is clear for $k = 3$, and follows from Observation 17 for $k \geq 5$).

1. By induction, there exists a recursive construction of $M - K$ such that the edge corresponding to e is the root. Upon inserting K , e is a root of M .
2. The inner edge of K can be a twin only of the outer edge of K . Then we continue inductively for $M - K$.

□

Theorem 21. *The number of I-matchings of size k is $\frac{1}{\ell} \binom{4\ell-2}{\ell-1}$ (where $\ell = \lceil \frac{k}{2} \rceil$).*

The proof of Theorem 21 is closely related to that of enumeration of L-matchings that will be introduced in Section 3.3. Therefore, these proofs will be given together (in Section 3.4).

3.3 Leaves

In this section we study the matchings that correspond to leaves – that is, vertices of degree 1 – in \mathbf{DCM}_k (for both odd and even values of k).

Definition. An *L-matching* is either a ring of size 2, a ring of size 3, or a matching of size $k \geq 4$ that can be obtained from an L-matching of size $k - 2$ by inserting a block in any place.

Theorem 22. *Let k be any natural number. A matching of size k is a leaf in \mathbf{DCM}_k if and only if it is an L-matching.*

Proof. For $k \leq 3$ the statement holds trivially or can be verified directly. Assume $k \geq 4$.

If M has no blocks, then by Proposition 15 (1) it has at least two neighbors and thus is not a leaf, and it is not an L-matching by definition.

If M has at least one block, the theorem follows from Proposition 12 which says that inserting a block doesn't change the degree. □

Thus, the recursive construction of L-matchings is very similar to that of I-matchings – only the basis is different. We define roots and twins for L-matchings similarly to the case of I-matchings, with the following difference. For even k , we do not define root, and the edges corresponding to the initial pair of edges will be also called twins. For odd k , the edges corresponding to the initial triple of edges will be called *the root triple*.

Proposition 23. *Let M be an L-matching.*

1. *For even k , the pairs of twins are determined uniquely.*
2. *For odd k , the root triple and the pairs of twins are determined uniquely.*

Proof. The pairs of twins and (in the odd case) the root triple form a flippable partition. Thus, the uniqueness follows in both cases from the fact that any L-matching is disjoint compatible to exactly one matching and, therefore, it has exactly one flippable partition. □

3.4 Enumeration of I- and L-matchings

Enumeration of I-matchings and L-matchings will be based on the following well-known result about non-crossing partitions. A *non-crossing partition* of a set of points in convex position is a partition of this set into non-empty subsets whose convex hulls do not intersect (thus, a non-crossing matching is essentially a non-crossing partition in which all the subsets are of size 2).

Theorem 24 (Essentially, a special case of a result by N. Fuss from 1791 [14]). *For $\ell \geq 0$, let a_ℓ be the number of non-crossing partitions of a set of 4ℓ labeled points in convex position into ℓ quadruples ($a_0 = 1$ by convention). Let $g(x) = a_0 + a_1x + a_2x^2 + \dots$ be the corresponding generating function. Then:*

1. The generating function $g(x)$ satisfies the equation

$$g(x) = 1 + xg^4(x). \quad (1)$$

2. The numbers a_ℓ are given by

$$a_\ell = \frac{1}{3\ell + 1} \binom{4\ell}{\ell}. \quad (2)$$

Remarks.

1. N. Fuss proved that for fixed $d \geq 2$, the number of dissections of a convex $((d-1)\ell + 2)$ -gon by its diagonals into ℓ $(d+1)$ -gons is $\frac{1}{(d-1)\ell+1} \binom{d\ell}{\ell}$, and (essentially) that the corresponding generating function satisfies the equation $g(x) = 1 + xg^d(x)$. These numbers are known as Pfaff-Fuss (or Fuss-Catalan) numbers. For $d = 2$, Catalan numbers are obtained. See [25, A062993] for this two-parameter array and [8] for a historical note on the topic. It is easy to see that the two structures – diagonal dissections of a convex $((d-1)\ell + 2)$ -gon into ℓ $(d+1)$ -gons *and* non-crossing partitions of $d\ell$ points in convex position into ℓ sets of size d , – have the same recursive structure (see [24, Exercise 6.19 (a) and (n)] for the case of $d = 2$). Thus, a_ℓ are Pfaff-Fuss numbers with $d = 4$.
2. Eq. (2) – rather in the form $\frac{1}{\ell} \binom{4\ell}{\ell-1}$ for $\ell \geq 1$ – follows from Eq. (1) by the Lagrange inversion formula [24, Theorem 5.4.2]. Indeed, Eq. (1) is equivalent to $x = \frac{\tilde{g}(x)}{(\tilde{g}(x)+1)^4}$ where $\tilde{g}(x) = g(x) - 1$. Therefore, if, following the notation as in the reference above, we take $F(x) = \frac{x}{(x+1)^4}$, or, equivalently, $G(x) = (x+1)^4$, and $k = 1$,⁶ we obtain $a_\ell = [x^\ell] \tilde{g}(x) = \frac{1}{\ell} [x^{\ell-1}] G^\ell(x) = \frac{1}{\ell} [x^{\ell-1}] (x+1)^{4\ell} = \frac{1}{\ell} \binom{4\ell}{\ell-1}$.

Theorem 21. *The number of I-matchings of size k is $\frac{1}{\ell} \binom{4\ell-2}{\ell-1}$ (where $\ell = \lceil \frac{k}{2} \rceil$).*

Theorem 25.

1. For odd k , the number of L-matchings of size k is $\frac{2}{3} \frac{\ell-1}{\ell} \binom{4\ell-2}{\ell-1}$ (where $\ell = \lceil \frac{k}{2} \rceil$).
2. For even k , the number of L-matchings of size k is $\frac{\ell+1}{3\ell+1} \binom{4\ell}{\ell}$ (where $\ell = \lceil \frac{k}{2} \rceil$).

⁶ This k from the statement of the Lagrange inversion formula in [24] is of course different from k as we use it in this paper.

Proof. It will be convenient to prove first Theorem 25 (2), then Theorem 21, and finally Theorem 25 (1).

A matching M and a non-crossing partition T of X_{2k} fit each other if every edge of M connects two points that belong to the same set of the partition T .

Proof of Theorem 25 (2). Let M be an L-matching of even size k . We saw in Proposition 23 that the edges of M can be partitioned into pairs of twins in a unique way. Replace each pair of twins by a quadruple of points. In this way we obtain a (unique) non-crossing partition of X_{2k} into ℓ quadruples that fits M .

Let T be any non-crossing partition of X_{2k} into ℓ quadruples. We show that there are exactly $\ell + 1$ L-matchings that fit T . For $k = 2$ ($\ell = 1$) there are 2 L-matchings, both fitting the (unique) non-crossing partition into quadruples. For $k \geq 4$ ($\ell \geq 2$) we proceed by induction as follows.

Let s be any quadruple of T that consists of four consecutive points $P_i, P_{i+1}, P_{i+2}, P_{i+3}$. (Such a quadruple will be called an *ear*. Each non-crossing partition with at least two parts has at least two ears.) For each L-matching of size $k - 2$ that fits $T \setminus \{s\}$, we can connect P_i with P_{i+3} and P_{i+1} with P_{i+2} . This is inserting a block, and, thus, an L-matching of size k is obtained. By induction, the number of matchings that we obtain in this way is ℓ .

In order to obtain one more matching, we connect first P_i with P_{i+1} and P_{i+2} with P_{i+3} . We show now that this can be completed to an L-matching in exactly one way. Namely, let s' be any quadruple of T ($s' \neq s$). Suppose that the points of s' are $P_\alpha, P_\beta, P_\gamma, P_\delta$ so that the cyclic order of the labels of the points of $S \cup S'$ satisfies $i + 4 \prec \alpha \prec \beta \prec \gamma \prec \delta \prec i$. Then we must connect P_α with P_δ and P_β with P_γ . Indeed, if we do that for each quadruple, an L-matching is obtained. In order to see that, erase an ear different from s . In this way a block is deleted from a matching, and then the induction applies. On the other hand, if in some s' we connect P_α with P_β and P_γ with P_δ , then we have two quadruples of T that contain a flippable pair and in both (with respect to the order of their union) the first point is connected to the second, and the third to the fourth. It is easy to see from the definition that this never happens in L-matchings.

To summarize: by Theorem 24, there are $\frac{1}{3\ell+1} \binom{4\ell}{\ell}$ non-crossing partitions of X_{2k} into ℓ quadruples, each such partition fits $\ell + 1$ L-matchings, and each L-matching is obtained in this way exactly once. Therefore, the number of L-matchings of size k is $\frac{\ell+1}{3\ell+1} \binom{4\ell}{\ell}$.

Proof of Theorem 21. First, each I-matching M has exactly one red edge $e = P_i P_j$ ($i < j$) such that all other edges of M either connect two points from the set $\{1, 2, \dots, i - 1\}$ (*appear before e*), or two points from the set $\{i + 1, i + 2, \dots, j - 1\}$ (*appear inside e*), or two points from the set $\{j + 1, j + 2, \dots, 2k\}$ (*appear after e*); such an edge will be called *the special red edge*. Indeed, this holds trivially for the matching of size 1, and this remains true when a block is inserted: if a block is inserted between P_α and $P_{\alpha+1}$ where $1 \leq \alpha \leq 2k - 1$, then (only) the edge corresponding to the old special red edge is special; and if a block is inserted between P_{2k} and P_1 , then the red edge of this block becomes the special one.

Let M be an I-matching and let $e = P_i P_j$ be its special red edge. By Proposition 20, there exists a recursive construction of M such that e is the root. Replace all the pairs of edges that were inserted as blocks at some step of this construction by quadruples. Then we have three non-crossing partitions of the corresponding sets of points into quadruples: one before e , one inside e , one after e . On the other hand, for each such partition, there is only one way to connect points of each quadruples by two edges in order to obtain an I-matching. Namely, for a quadruple $P_\alpha, P_\beta, P_\gamma, P_\delta$ with $\alpha < \beta < \gamma < \delta$ we must connect P_α with P_δ and P_β with P_γ . The proof is similar to that above: the points of an ear must be connected in this way (otherwise the conclusion of Proposition 19 (3)

is not satisfied), and then induction applies.

Thus, three non-crossing partitions of points before, inside, and after e into quadruples determine uniquely an I-matching. It follows that the generating function for the number of such matchings is $xg^3(x)$, where $g(x)$ is the function from Theorem 24. In order to calculate its coefficients, we use the general form of the Lagrange inversion formula [24, Corollary 5.4.3] with $G(x) = (x + 1)^4$, $H(x) = (x + 1)^3$ (so that $g^3(x) = H(\tilde{g}(x))$), and $k = 3$.⁷ We obtain

$$[x^\ell]xg^3(x) = [x^{\ell-1}]g^3(x) = [x^{\ell-2}]\frac{1}{\ell-1}H'(x)G^{\ell-1}(x) = \frac{3}{\ell-1}[x^{\ell-2}](x+1)^{4\ell-2} = \frac{3}{\ell-1}\binom{4\ell-2}{\ell-2},$$

which is equal to $\frac{1}{2}\binom{4\ell-2}{\ell-1}$ for $\ell > 1$.

Remark. This sequence of numbers is [25, A006632], where it appears with a reference to a paper by H. N. Finucan [11]. In that paper, it counts the number of nested systems (“stackings”) of ℓ folders with 3 compartments such that exactly one folder is outer (“visible”). There is a very simple bijection between two structures, see Figure 9 for an example: pairs of twins are converted into 3-compartment folders; the special red edge forms a pair with the outer part of Γ , and it is converted to the outer folder.

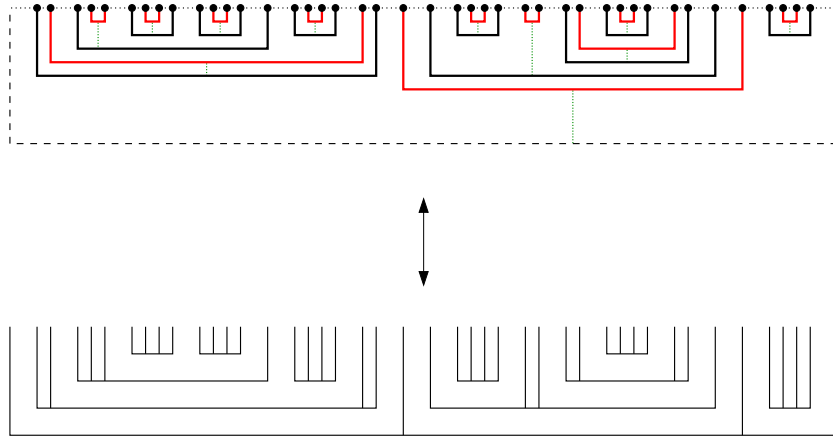

Figure 9: An example illustrating the bijection between I-matchings of size $k = 2\ell - 1$ and stackings of ℓ 3-folders with only one outer folder.

Proof of Theorem 25 (1). The proof will be based on the previous one (notice the similarity of the expressions in these two theorems). Essentially, we describe a way to convert I-matchings into L-matchings of odd size, and take care of multiplicities.

Let M be an I-matching of size $k \geq 3$. Each black edge belongs to two faces, and, by Observation 19 (4), each of these faces has exactly one red edge. Such a triple of edges – a black edge e and the red edges incident to the faces incident to e – will be called a RBR-triple.⁸ By Observation 19 (3), there are $\ell - 1$ black edges in M ; therefore, there are also $\ell - 1$ RBR-triples. Therefore, there are $\frac{\ell-1}{\ell}\binom{4\ell-2}{\ell-1}$ I-matchings of size k with a marked RBR-triple.

Suppose that the endpoints of the edges that belong to an RBR-triple are (according to the cyclic order) $Q_1, Q_2, Q_3, Q_4, Q_5, Q_6$. Then the RBR-triple can be one of the following: $\{Q_1Q_2, Q_3Q_6, Q_4Q_5\}$,

⁷The same remark as in footnote 6 applies.

⁸RBR stands for red-black-red.

$\{Q_1Q_4, Q_2Q_3, Q_5Q_6\}$, or $\{Q_1Q_6, Q_2Q_5, Q_3Q_4\}$. It is easy to see that if we replace these edges by either $\{Q_1Q_2, Q_3Q_4, Q_5Q_6\}$ or $\{Q_2Q_3, Q_4Q_5, Q_6Q_1\}$, an L-matching is obtained. Thus, we have obtained $2\frac{\ell-1}{\ell}\binom{4\ell-2}{\ell-1}$ L-matchings.

However, each L-matching is obtained in this way exactly three times. Indeed, by Proposition 23 (2), the root triple of an L-matching is determined uniquely. It can be replaced by a RBR-triple in three ways, each of them producing an I-matching. Therefore, the number of L-matchings of size k (for odd k) is $\frac{2}{3}\frac{\ell-1}{\ell}\binom{4\ell-2}{\ell-1}$. \square

3.5 Strip Drawings and DB-components

In the following sections, we shall frequently use a special way to draw matchings – *strip drawings*, that were already used in the end of Section 3.1. In such a drawing Γ is an axis-aligned rectangle \mathbf{R} , and all the points of X_{2k} lie on its horizontal sides (the lower side will be denoted by \mathbf{L} , the upper by \mathbf{U}). The edges that connect a point from \mathbf{L} with a point of \mathbf{U} will be represented by vertical segments; such edges will be called *D-edges*. In some cases, in order to achieve a drawing in which all the D-edges are vertical, we'll move some points of X_{2k} along \mathbf{L} or \mathbf{U} . If a D-edge connects the leftmost (respectively, the rightmost) points of X_{2k} on \mathbf{L} and on \mathbf{U} , we will assume that it lies on the left (respectively, the right) side of \mathbf{R} . The edges that connect neighboring points of \mathbf{L} or of \mathbf{U} will be represented by horizontal segments that lie on Γ ; such edges will be called *B-edges*.⁹ Edges that connect non-neighboring points of \mathbf{L} or of \mathbf{U} will be represented, as usually, by Jordan curves inside $\mathbf{O}(\Gamma)$. The index of the leftmost point of \mathbf{U} will be denoted by z , and, as agreed earlier, the points are labeled cyclically clockwise.

Obviously, each matching can be represented by a strip drawing, but we shall use them only for certain classes of matchings, when such drawings can be made especially simple and clear. As mentioned earlier, the fact that all the boundary edges lie on Γ is inconsistent with our original definitions. In particular, as a planar map, such a drawing “looses” all the boundary faces (therefore it will be called a *reduced map*). However, strip drawings are very useful due to the following fact. As mentioned above, a flippable set is a subset of the set of edges that belong to the same face. On the other hand, a flippable set is always of size at least 2. Thus, reduced maps have no faces that cannot contribute to a flippable partition, and, thus, the candidates for flippable sets will be clearly seen.

An *element* in a strip drawing is a subset of edges that can be separated from other edges by straight lines. We distinguish the following kinds of elements; they will be used later for describing of certain kinds of matchings. Refer to Figure 10. A *DB-element* in an element of size 2 that consists of a D-edge d and a B-edge b . There are four kinds of DB-elements, distinguished by their *direction* and *position* as follows. The direction is R if b is to the right of d , L if b is to the left of d . The position is $-$ if b lies on \mathbf{L} , and $+$ if b lies on \mathbf{U} . A *DBD-element* is an element of size 3 that consists of two D-edges d_1, d_2 , and one B-edge b between them. The position of a DBD-element is $-$ (respectively, $+$) if b lies on \mathbf{L} (respectively, on \mathbf{U}). A *B²⁺¹-element* is an element of size 3 that consists of three B-edges: two on \mathbf{L} and one on \mathbf{U} (then its position is $-$), or vice versa (then its position is $+$). An *EDB-element* is an element of size 4 that consists of three B-edges forming a B²⁺¹-element and a D-edge to the left or to the right of them. The direction of an EDB-element is R (respectively, L) if the B-edges are to the right (respectively, to the left) of the D-edge; its

⁹ *D* and *B* stand for “diagonal” and “boundary”, since a B-edge is always a boundary edge, and a D-edge is *usually* a diagonal edge (the exceptional situation is when it connects the leftmost or the rightmost points of \mathbf{L} and \mathbf{U}).

position agrees with that of the B^{2+1} element. Notice that DB-, EDB-, DBD- and B^{2+1} -elements are always flippable sets. The next observation summarizes the effect of flipping these elements.

Observation 26.

1. The set obtained from a DB-element by flipping is a DB-element with the same position and different direction.
2. The set obtained from an EDB-element by flipping is an EDB-element with the same position and different direction.
3. The set obtained from a DBD-element by flipping is a B^{2+1} -element with the same position, and vice versa.

See Figure 10 for illustration. Notice that in some cases we modify the point set in order to draw a D-edge as a vertical segment. On the first strip, given elements are shown; on the second, the elements obtained from them by flipping; on the third, they are shown after modifying the point set.

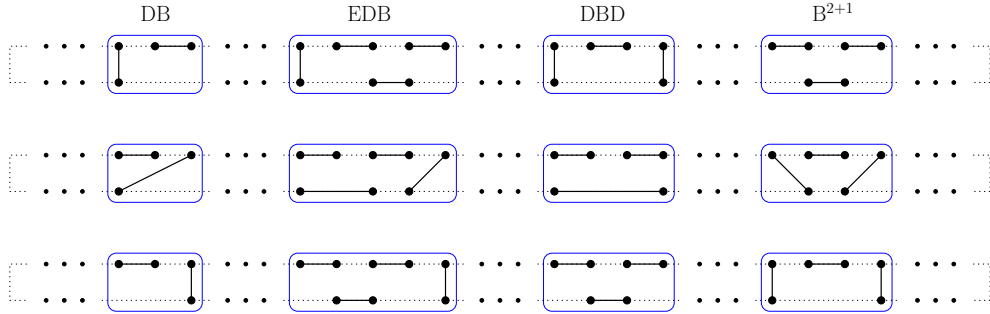

Figure 10: DB-, EDB-, DBD-, and B^{2+1} -elements, and flipping them.

The structure of some simple matchings can be partially described by their *pattern* – a sequence of elements of these types (to be read from left to right). For example, we say that a strip drawing has pattern $DBDB^{2+1}D$ if it consists of three D-edges d_1, d_2, d_3 , a B-edge between d_1 and d_2 , and a B^{2+1} -element between d_2 and d_3 . Notice that the pattern does not determine a drawing uniquely since the labeling of points and the position of B-edges is not indicated.

3.6 Small components for even k (Pairs)

By Proposition 14, a matching of even size is never isolated. As we shall show now, for any even k there are matchings of size k that belong to *pairs* – connected components of size 2. Thus, we next define a family of matchings and prove that they indeed form the small components of \mathbf{DCM}_k for even values of k .

Definition. Let k be an even number. A *DB-matching* of size k is a matching that can be represented by a strip drawing with pattern $DBDB \dots DB$ – that is, consists of ℓ ($= \lceil \frac{k}{2} \rceil$) R-directed DB-elements.

A drawing as in this definition will be the *standard drawing* for a DB-matching. If instead of R-directed DB-elements we have L-directed DB-elements, this is an *upside-down drawing* of a

DB-matching; the standard one can be obtained from it by 180° rotation. The edges of the i th (from left to right) DB-element in the standard drawing of a DB-matching will be denoted by d_i, b_i . The map of M has ℓ inner faces and $\ell + 1$ boundary faces. The inner faces will be denoted by D_1, D_2, \dots, D_ℓ : for $1 \leq i \leq \ell - 1$, D_i is the face whose edges are d_i, b_i, d_{i+1} ; D_ℓ is the face whose edges are d_ℓ, b_ℓ . The boundary faces will be denoted by B_0, B_1, \dots, B_ℓ : B_0 is the face whose only edge is d_1 ; for $1 \leq i \leq \ell$, B_i is the face whose only edge is b_i .

In a DB-matching of size $k \geq 4$, $\{d_1, b_1\}$ is an antiblock, and $\{d_\ell, b_\ell\}$ is a block, and there are no other separated pairs. Therefore, the position ($-$ or $+$) of these extremal DB-elements can be chosen arbitrarily: changing the position of $\{d_\ell, b_\ell\}$ does not change the matching, and changing the position of $\{d_1, b_1\}$ results in a rotationally isomorphic matching. For $k \geq 4$, we shall always draw the antiblock as a DB-element of type $R+$, and the block as a DB-element of type $R-$. Different choices of position in all other DB-elements produce rotationally non-equivalent matchings. Their positions will be encoded by a $\{-, +\}$ -sequence $\chi = (x_1, x_2, \dots, x_{\ell-2})$, where x_i is the position of the $(i + 1)$ st DB-element. The DB-matching of size k with specified χ and z (the label of the leftmost point on \mathbf{U}) will be denoted by $\text{DB}(k, \chi, z)$.¹⁰

The dual trees of DB-matchings have the following structure (we denote the vertices of $D(M)$ identically to the corresponding faces of the map of M): There is a path $B_0 D_1 D_2 \dots D_\ell$ (imagined as consisting of horizontal edges so that B_0 is on the left and D_ℓ is on the right); and for each i , $1 \leq i \leq \ell$, a leaf B_i is attached to D_i . As explained above, by convention B_1 is attached to D_1 above the path, and B_ℓ is attached to D_ℓ below the path; and for $2 \leq i \leq \ell - 1$, B_i can be attached to D_i in two ways: either below or above the path. See Figure 11: (a) shows the matching $\text{DB}(14, - + + - +, 1)$ represented by its standard strip drawing; (b) shows its dual tree; (c) shows the general structure of the dual tree of DB-matchings (dashed edges $D_i B_i$, $2 \leq i \leq \ell - 1$, indicate that each of them can be either below or above the path $B_0 D_1 \dots D_\ell$).

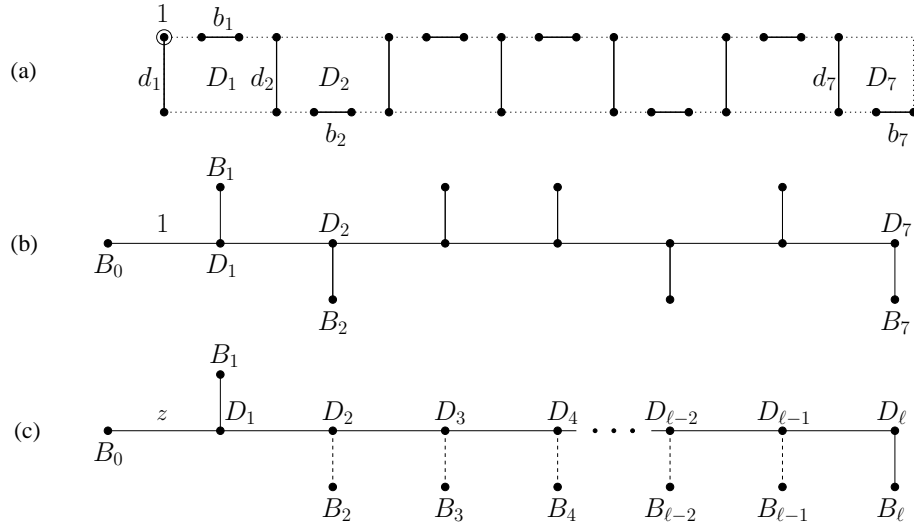

Figure 11: (a) The matching $\text{DB}(14, - + + - +, 1)$. (b) The dual tree of $\text{DB}(14, - + + - +, 1)$. (c) The general structure of the dual tree of DB-matchings.

¹⁰Note that k is determined by the length of χ and, therefore, can be omitted. However, we find it convenient to include it in our notation.

For a $\{-, +\}$ -sequence χ , we denote by χ' the sequence obtained from χ by reversing and changing all the components, and we denote $\delta(\chi) = \#\chi(+) - \#\chi(-)$. For example, for $\chi = (+ + - + + - - +)$ we have $\chi' = (- + + - - + - -)$ and $\delta(\chi) = 2$.

Theorem 27. *Let k be an even number. A matching of size k belongs to a pair in \mathbf{DCM}_k if and only if it is a DB-matching.*

Proof. For $k = 2$ the statement is obvious. Thus, we assume $k \geq 4$.

[\Leftarrow] Assume that M is a DB-matching of size k . First we show that it is an L-matching. The rightmost DB-element of M , $K = \{d_\ell, b_\ell\}$, is a block. The matching $M - K$ is also a DB-matching, and, therefore it is an L-matching by induction. Therefore, M is also an L-matching, that is, it has degree 1 in \mathbf{DCM}_k . Its only flippable partition consists of the DB-elements $\{d_i, b_i\}$.

Denote the only neighbor of M by M' . By Observation 26, M' is obtained from M by replacing each of its DB-elements by the L-directed DB-element of the same position. This means that M' , drawn on the same strip drawing, is also a DB-matching, but drawn upside down. In order to obtain its standard representation, we rotate the drawing. χ is replaced then by χ' , and z by the label of the rightmost point on \mathbf{L} in the standard drawing of M , which is $z' = z + k + \delta(\chi)$.¹¹ Thus, we obtain $M' = \text{DB}(k, \chi', z')$. See Figure 12 for an illustration (the flippable sets are marked by blue color; the asterisk indicates an upside down drawing).

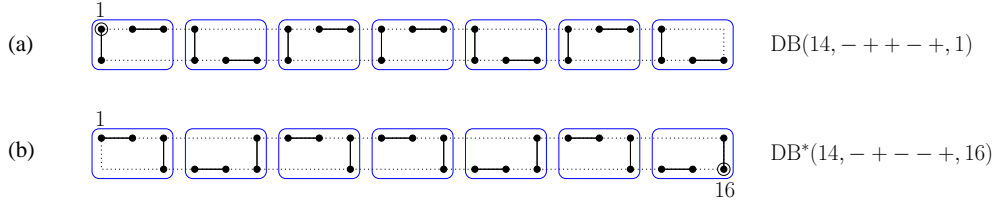

Figure 12: Two DB-matchings forming a pair: (a) $\text{DB}(14, - + + - +, 1)$, (b) $\text{DB}(14, - + - - +, 16)$ (drawn upside down).

Since M' is also a DB-matching, it is adjacent to only one matching, namely, to M . Thus, M and M' form a pair in \mathbf{DCM}_k .

[\Rightarrow] Assume that M belongs to a pair. M has at least one block, as otherwise it is adjacent to at least two distinct matchings by Proposition 15 (1). Fix a block K in M , and denote $N = M - K$. If N is not a DB-matching, then, by induction and by Proposition 14, it is connected (by a path) to at least two matchings. Then M is connected (by a path) to at least two matchings by Proposition 13, and this is a contradiction.

Now assume that N is a DB-matching (of size $k - 2$). We shall see that either M is a DB-matching, or M can be decomposed in a different way, $M = L + P$, where P is a separated pair, and L is **not** a DB-matching (which will be shown by indicating an element which never occurs in DB-matchings). In the former case this completes the proof, in the latter case we obtain a contradiction as above (with L in role of N and P in the role of K).

Consider the dual tree of N . Then $D(K)$, the part that corresponds to K , is a 2-branch attached to $D(N)$ in some point (see Figure 13). Label the points of $D(N)$ in accordance to our

¹¹Indeed, let $u = \#\chi(+)$, $d = \#\chi(-)$. Then the number of points on \mathbf{U} is $3u + d = 2(u + d) + (u - d) = k + \delta(\chi)$.

usual notation, as in Figure 11 (notice that it consists of $\ell - 1$ rather than of ℓ DB-elements). Now we have the following subcases.

- (a) $D(K)$ is attached to $D(N)$ at B_i , $0 \leq i \leq \ell - 2$. Let P be the block $D_{\ell-2}D_{\ell-1}B_{\ell-1}$,¹² and let $L = M - P$. Then $D(L)$ has a 3-branch, and, therefore, L is not a DB-matching.
- (b) $D(K)$ is attached to $D(N)$ at D_i , $1 \leq i \leq \ell - 3$. Let P be the block $D_{\ell-2}D_{\ell-1}B_{\ell-1}$, and let $L = M - P$. Then $D(L)$ has a vertex of degree 4, and, therefore, L is not a DB-matching.
- (c) $D(K)$ is attached to $D(N)$ at $D_{\ell-2}$. Let P be the antiblock $B_0D_1B_1$, and let $L = M - P$. Then $D(L)$ has a vertex of degree 4, and, therefore, L is not a DB-matching.
- (d) $D(K)$ is attached to $D(N)$ at $D_{\ell-1}$. Then M is a DB-matching.
- (e) $D(K)$ is attached to $D(N)$ at $B_{\ell-1}$. Let P be the antiblock $B_0D_1B_1$, and let $L = M - P$. Then $D(L)$ has a 4-chain, and, therefore, L is not a DB-matching.

These cases are shown in Figure 13. $D(K)$ is shown by green when M is a DB-matching, and by blue when a contradiction is obtained. In this latter case, the element corresponding to P is marked by red. The point where $D(K)$ is attached to $D(N)$ is marked by a circle. \square

Theorem 28. *The number of DB-matchings of size k is $\ell \cdot 2^\ell$.*

Proof. For a DB-matching of size k , χ can be chosen in $2^{\ell-2}$ ways, and z in $2k = 4\ell$ ways. Since the structure of a DB-matching has no non-trivial symmetries, each DB-matching is counted in this way exactly once. Therefore, there are $2^{\ell-2} \cdot 4\ell = \ell \cdot 2^\ell$ DB-matchings. \square

The number of small components in \mathbf{DCM}_k is obtained now immediately.

Corollary 29. *The number of small components in \mathbf{DCM}_k is $\ell \cdot 2^{\ell-1}$.*

4 Medium components

4.1 Medium components for odd k

Definition. Let $k \geq 3$ be an odd number. A *DBD-matching* of size k is a matching that can be represented by a strip drawing with pattern $\mathbf{DBDB} \dots \mathbf{DBD}$. In other words, its strip drawing can be obtained from the standard strip drawing of a DB-matching of size $k - 1$ by adding one more D-element that connects the rightmost points of \mathbf{L} and \mathbf{U} .

For DBD-matchings, we adopt the notations and the conventions developed for DB-matchings and their standard drawings. One difference is that this time the edges of (the rightmost) face $D_{\ell-1}$ are $d_{\ell-1}, b_{\ell-1}, d_\ell$. Similarly to DB-matchings, it will be assumed without loss of generality that b_1 lies on \mathbf{U} , and $b_{\ell-1}$ lies on \mathbf{L} , and the position of other b_i s will be specified by a $\{-, +\}$ -sequence χ (which is now of length $\ell - 3$). A DBD-matching with specified χ and z will be denoted by $\mathbf{DBD}(k, \chi, z)$. Notice, however, that due to a symmetry of the structure each DBD-matching is represented twice in this form: $\mathbf{DBD}(k, \chi, z) = \mathbf{DBD}(k, \chi', z')$ (or, more precisely, the standard

¹²For the sake of brevity, we write “the block/the antiblock ABC ” instead of “the block/the antiblock corresponding to the 2-branch/the V-shape ABC ”.

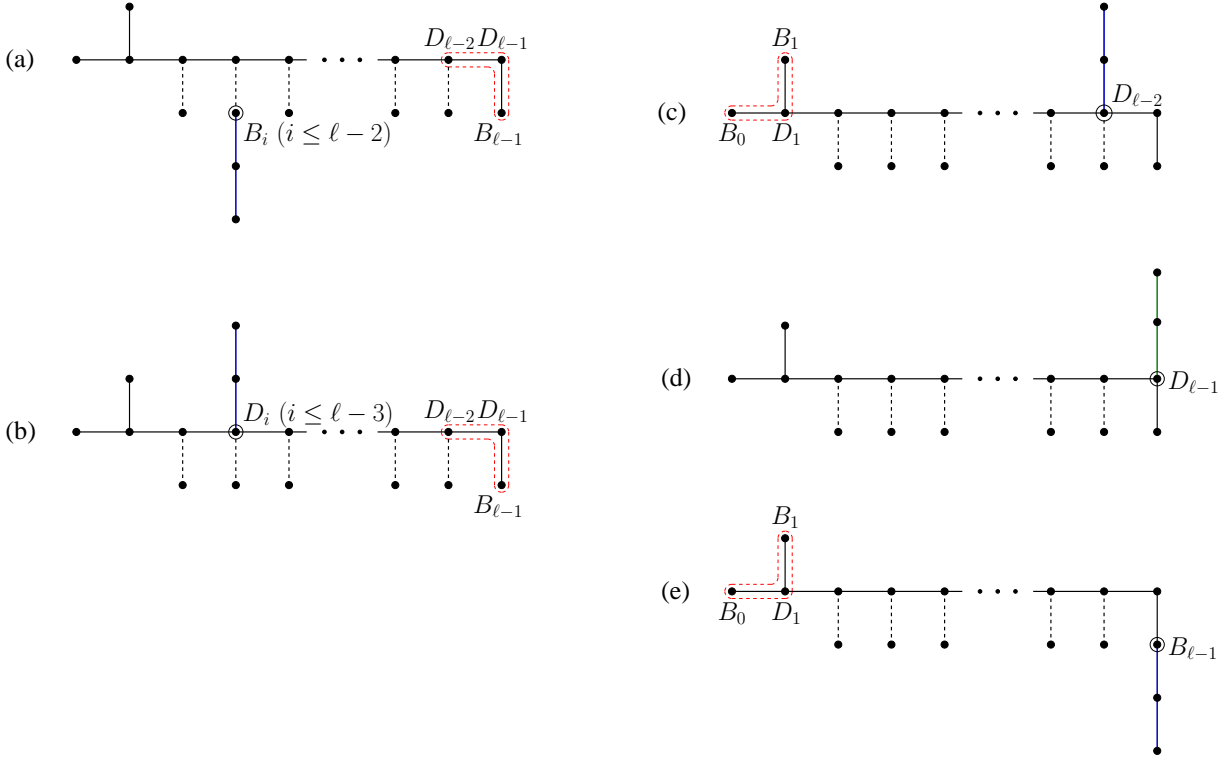

Figure 13: Illustration to the proof of Theorem 27.

drawing of $\text{DBD}(k, \chi, z)$ is the upside down drawing of $\text{DBD}(k, \chi', z')$, where χ' and z' are defined as for DB-matchings. See Figure 14: (a) shows the matching $\text{DBD}(15, ++--+, 1)$ represented by a standard strip drawing (this matching is also $\text{DBD}(15, -++-- , 17)$ drawn upside down), (b) shows the dual tree of $\text{DBD}(15, ++--+, 1)$, (c) shows the general structure of the dual tree of DBD-matchings.

Proposition 30. *Let M be a DBD-matching of size k . Then:*

1. M has exactly $\ell - 1$ neighbors (where $\ell = \lceil \frac{k}{2} \rceil$);
2. All the neighbors of M are leaves.

Thus, the connected component that contains M is a star of order ℓ .

Proof.

1. Let M' be a (supposed) neighbor of M . Consider the corresponding flippable partition of M . Its members can be of size at most 3 because inner faces of M have at most three edges. Since k is odd, there is at least one set of size 3 in the flippable partition, which must be a DBD-element $\{d_j, b_j, d_{j+1}\}$ ($1 \leq j \leq \ell - 1$). The parts of M to the left and to the right of this DBD-element are DB-matchings (if non-empty), and, therefore, upon the choice of a DBD-element that belongs to a flippable partition, the construction of a disjoint compatible

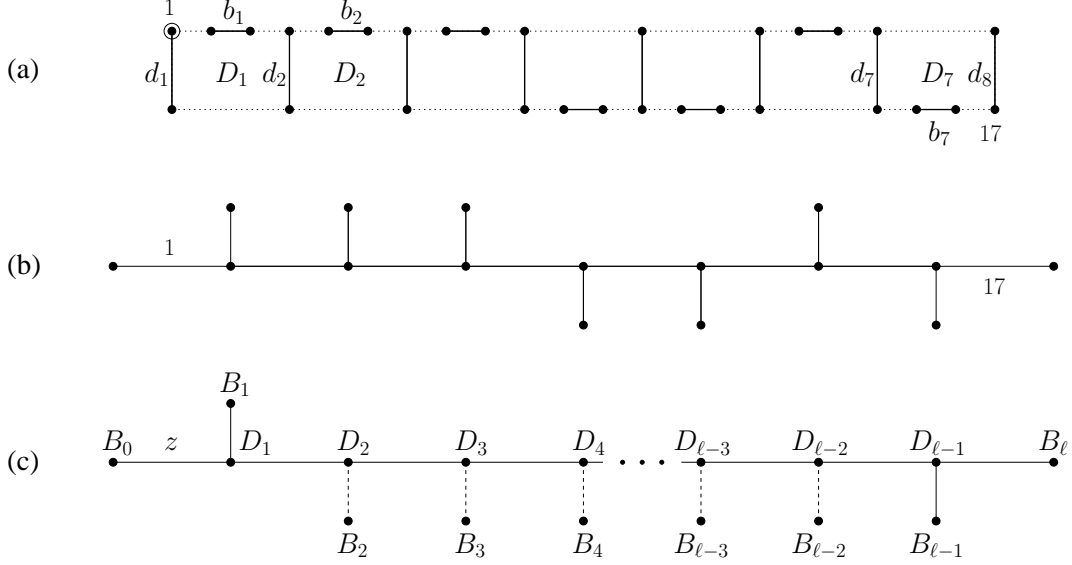

Figure 14: DBD-matchings: (a) $\text{DBD}(15, ++--+, 1)$; (b) The dual tree of $\text{DBD}(15, ++--+, 1)$. (c) The general structure of the dual tree.

matching can be completed in a unique way. Since M , with this flippable partition (shown by square brackets) has the pattern

$$\underbrace{[\text{DB}] \dots [\text{DB}]}_{(j-1) \times \text{DB}} [\text{DBD}] \underbrace{[\text{BD}] \dots [\text{BD}]}_{(\ell-1-j) \times \text{BD}},$$

the matching M' determined by flipping the j th DBD-element has by Observation 26 the pattern

$$\underbrace{[\text{BD}] \dots [\text{BD}]}_{(j-1) \times \text{BD}} [\text{B}^{2+1}] \underbrace{[\text{DB}] \dots [\text{DB}]}_{(\ell-1-j) \times \text{DB}}.$$

The position of B-edges of M' matches that of M . Denote this matching M' by $\text{DBDL}(k, j, \chi, z)$.

The dual tree of $M' = \text{DBDL}(k, j, \chi, z)$ is obtained from that of $M = \text{DBD}(k, \chi, z)$ by erasing the edges $B_0 D_1$ and $D_{\ell-1} B_\ell$, and attaching two additional leaves, one below the path and one above it, to D_j . The edge side $D_1 B_1$ is labeled by z .

Since we have $\ell - 1$ ways to choose the DBD-element that belongs to a flippable partition, M has $\ell - 1$ neighbors.

2. We see inductively that the only flippable partition of a DBDL-matching consists of $\ell - 2$ DB-elements and one B^{2+1} -element. Therefore, it has only one neighbor, and, thus, it is an L-matching. □

Figure 15 shows the matching $\text{DBD}(11, ++-, 1)$, its neighbors $\text{DBD}(11, j, ++-, 1)$, $1 \leq j \leq 5$, and their dual trees. For the DBDL-matchings, the flippable sets are marked by a blue box.

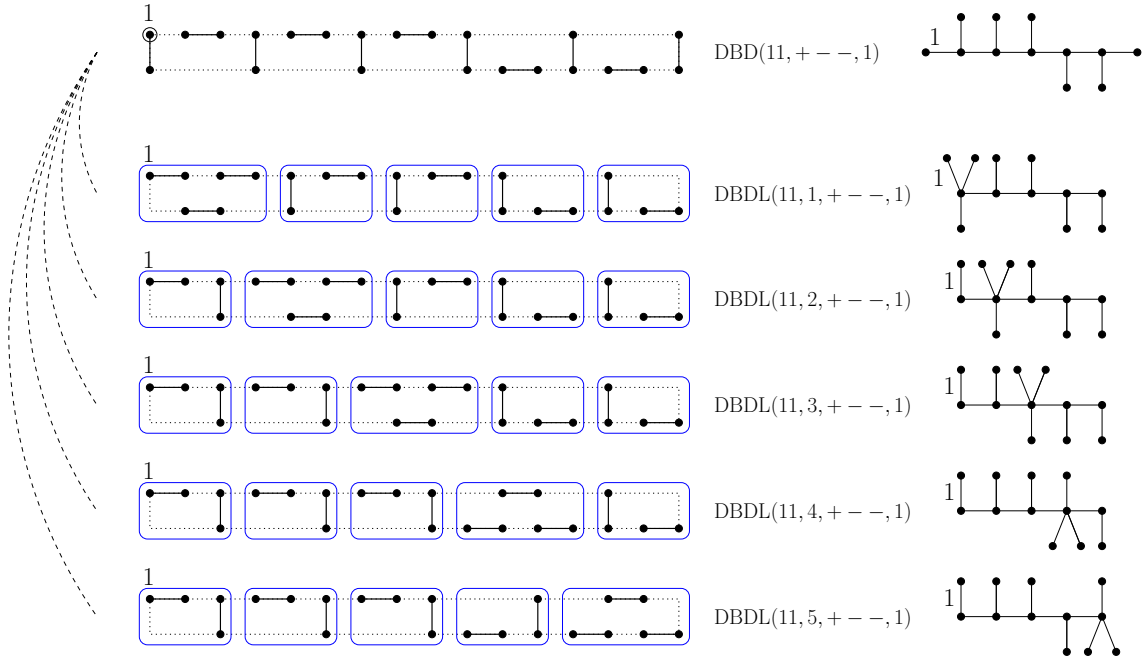

Figure 15: The matching $\text{DBD}(11, + + -, 1)$, its neighbors, and their dual trees.

Proposition 31. *The number of DBD-matchings of size k is $(2\ell - 1) \cdot 2^{\ell-3}$.*

Proof. For a DBD-matching of size k , χ can be chosen in $2^{\ell-3}$ ways, and z in $2k = 2(2\ell - 1)$ ways. However, as explained above, $\text{DBD}(k, \chi, z) = \text{DBD}(k, \chi', z')$, and this is the only way to represent a DBD-matching by a standard strip drawings in several ways. Therefore, each DBD-matching is represented in this way exactly twice. It follows that there are $(2\ell - 1) \cdot 2^{\ell-3}$ DBD-matchings. \square

Corollary 32. *The number of connected components of DCM_k that contain DBD- and DBDL-matchings is $(2\ell - 1) \cdot 2^{\ell-3}$.*

To summarize: In this section we described certain connected components of DCM_k for odd values of k . The enumerational results fit those from Table 1. In Section 5 we will show that these are precisely the medium components of DCM_k for odd k .

4.2 Medium components for even k

Recall the definition of DB-matching from Section 3.6. Refer again to Figure 11 for the standard representation of a DB-matching by a strip drawing, and for the labeling of its edges and faces. In particular, the standard drawing of a DB-matching of size $k - 2$ has $\ell - 1$ faces $D_1, \dots, D_{\ell-1}$ (from left to right).

Definition. An *EDB-matching*¹³ of size k is a matching whose (standard) stripe drawing can be obtained from that of a DB-matching of size $k - 2$ by adding two boundary edges to one of the faces

¹³EDB stands for “extended DB-matching”.

D_j ($1 \leq j \leq \ell - 1$), one on \mathbf{U} and one on \mathbf{L} (or, equivalently, by replacing one of its DB-elements by an EDB-element of the same direction and position).

Thus, a DB-matching of size $k - 2$ produces $\ell - 1$ EDB-matchings of size k . Specifically, let $\text{DB}(k - 2, \chi, z)$ be a DB-matching. For each j , $1 \leq j \leq \ell - 1$, we denote by $\text{EDB}(k, j, \chi, z)$, the matching obtained from $\text{DB}(k - 2, \chi, z)$ by adding two boundary edges, as explained above, to D_j . These two boundary edges will be denoted by e and e' : e lies on the same side of \mathbf{R} as b_j (in order to distinguish between b_j and e we assume that e is to the left of b_j), and e' on the opposite side.

Equivalently, the dual tree of an EDB-matching of size k can be obtained from the dual tree of a DB-matching of size $k - 2$ by attaching a pair of leaves, E and E' , one below and one above the path $B_0 \dots D_{\ell-1}$, to one of the vertices D_j , $1 \leq j \leq \ell - 1$ (the edges $D_j E$ and $D_j E'$ correspond, respectively, to e and e'). See Figure 16 for an example.

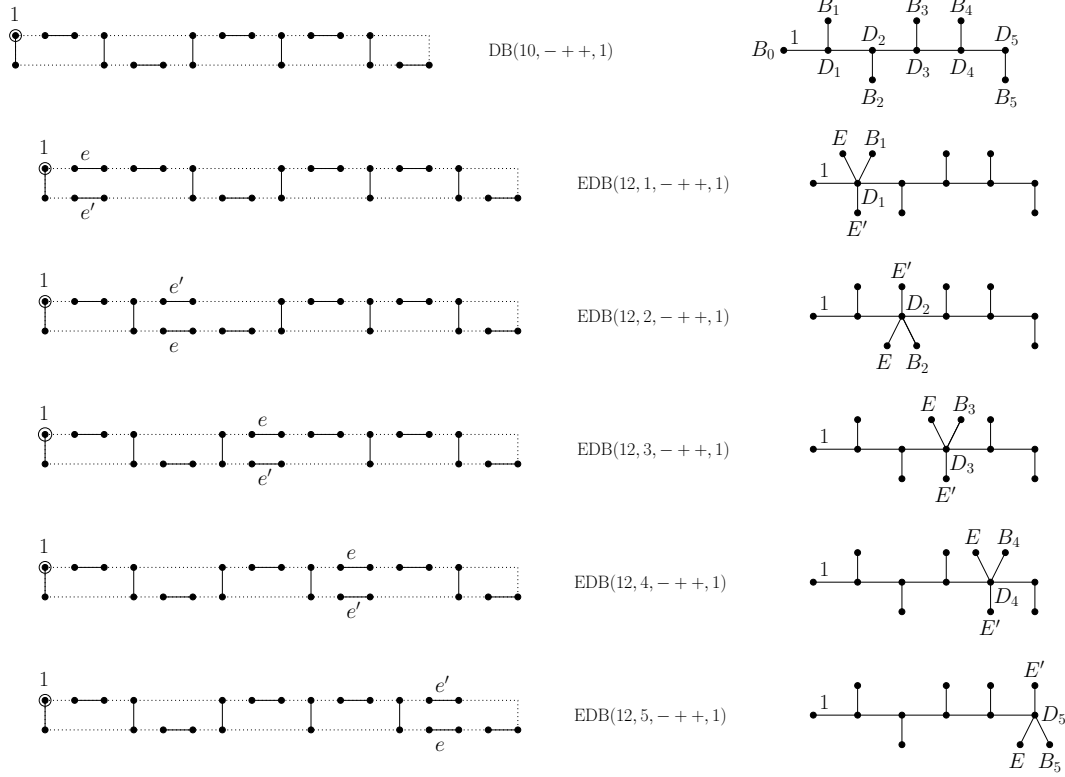

Figure 16: The five EDB-matchings $\text{EDB}(12, j, - + +, 1)$, $j = 1, 2, 3, 4, 5$, produced by $M = \text{DB}(10, - + +, 1)$.

Recall from the proof of Theorem 27 that the only neighbor of $\text{DB}(k - 2, \chi, z)$ is $\text{DB}(k - 2, \chi', z')$, where $z' = z + (k - 2) + \delta(\chi)$.

Proposition 33. *The EDB-matching $M = \text{EDB}(k, j, \chi, z)$ has $j + 2$ neighbors, namely:*

- j EDB-matchings, namely, $\text{EDB}(k, i, \chi', z')$ for $\ell - j \leq i \leq \ell - 1$ (here $z' = z + k + \delta(\chi)$);
- and two L -matchings.

Proof. Consider the standard strip drawing of $M = \text{EDB}(k, j, \chi, z)$. Let M' be a (supposed) neighbor of M . The set $P = \{d_j, b_j, e, e'\}$ is an R-directed EDB-element of M . The part of M to the right of P is (if non-empty) a DB-matching consisting of R-directed DB-elements, and, therefore, they are replaced in M' by L-directed DB-elements with the same position. The edges of P can belong to the sets from a flippable partition in several ways. There are several cases to consider.

- **Case 1: The quadruple $P = \{d_j, b_j, e, e'\}$ belongs to the flippable partition.** P , the R-directed EDB-element of M , is replaced in M' by an L-directed EDB-element with the same position. If there are edges to the left of P , they form a DB-matching consisting of R-directed DB-elements. Thus, in M' they are replaced in M' by L-directed elements with the same position. Since M with its flippable partition has the form

$$\underbrace{[\text{DB}] \dots [\text{DB}]}_{j \times \text{DB}} [\text{DB}^{2+1}] \underbrace{[\text{DB}] \dots [\text{DB}]}_{(\ell-1-j) \times \text{DB}},$$

we obtain that M' has the form

$$\underbrace{[\text{BD}] \dots [\text{BD}]}_{j \times \text{BD}} [\text{B}^{2+1}\text{D}] \underbrace{[\text{BD}] \dots [\text{BD}]}_{(\ell-1-j) \times \text{BD}},$$

that is, M' is also an EDB-matching (drawn upside down), namely, $M' = \text{EDB}(k, \ell-j, \chi', z')$. See Figure 17 for an example.

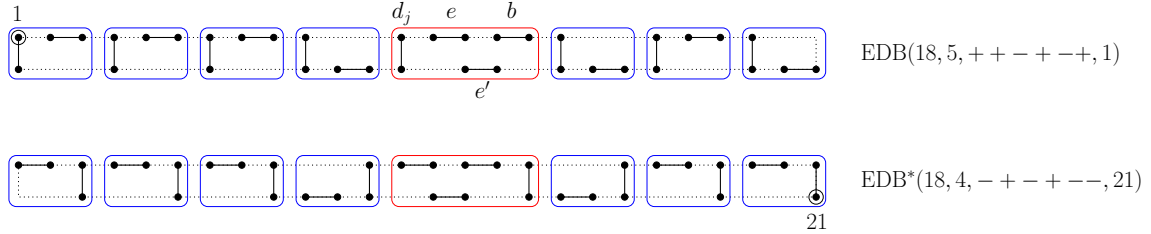

Figure 17: $\text{EDB}(18, 5, ++-+-+, 1)$ and its neighbor $\text{EDB}(18, 4, -+-+--, 21)$ determined by flipping a quadruple (Proposition 33, case 1).

- **Case 2: The triple $\{b_j, e, e'\}$ belongs to the flippable partition.** This triple is a B^{2+1} -element. Upon flipping it, we obtain in M' a DBD-element with the same position. The part of M to the left of this triple, is (if non-empty) a DBD-matching of size $2j - 1$. Therefore, it follows from the proof of Proposition 30, that M' is determined by flipping another flippable DBD-element $\{d_i, b_i, d_{i+1}\}$ for some $1 \leq i \leq j - 1$. Since M has the form

$$\underbrace{[\text{DB}] \dots [\text{DB}]}_{(i-1) \times \text{DB}} [\text{DBD}] \underbrace{[\text{BD}] \dots [\text{BD}]}_{(j-i) \times \text{BD}} [\text{B}^{2+1}] \underbrace{[\text{DB}] \dots [\text{DB}]}_{(\ell-1-j) \times \text{DB}},$$

we obtain that M' has the form

$$\underbrace{[\text{BD}] \dots [\text{BD}]}_{(i-1) \times \text{BD}} [\text{B}^{2+1}] \underbrace{[\text{DB}] \dots [\text{DB}]}_{(j-i) \times \text{DB}} [\text{DBD}] \underbrace{[\text{BD}] \dots [\text{BD}]}_{(\ell-1-j) \times \text{BD}},$$

which can be rewritten as

$$\underbrace{\text{BD} \dots \text{BD}}_{(i-1) \times \text{BD}} \text{B}^{2+1} \text{D} \underbrace{\text{BD} \dots \text{BD}}_{(\ell-i) \times \text{BD}},$$

which means that M' is also an EDB-matching (drawn upside down), namely – since the position of the flipped elements didn't change, – $M' = \text{EDB}(k, \ell - i, \chi', z')$.

Since the flippable DBD-element can be chosen in $j - 1$ ways, we obtain in this case $j - 1$ neighbors of M . See Figure 18 for an example (the flipped triples are indicated by red boxes around the matchings adjacent to M).

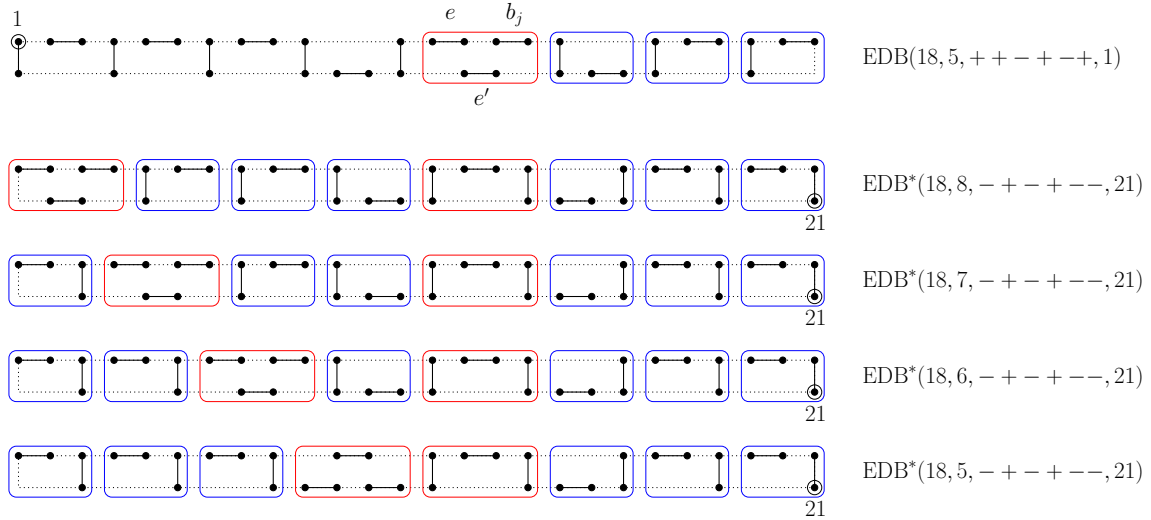

Figure 18: $\text{EDB}(18, 5, + + - + - +, 1)$ and its neighbors $\text{EDB}(18, j, - + - + ---, 21)$, $5 \leq j \leq 8$, determined by flipping two triples (Proposition 33, case 2).

- **Case 3a: Two pairs, $\{b_j, e\}$ and $\{d_j, e'\}$, belong to the flippable partition.**

$M \setminus \{b_j, e\}$ is the DB-matching obtained from $\text{DB}(k - 2, \chi, z)$ by changing the position of its j th DB-element. Thus, the neighbor of $M \setminus \{b_j, e\}$ is the DB-matching obtained from $\text{DB}(k - 2, \chi', z')$ by changing the position of its $(\ell - j)$ th DB-element. The antiblock $\{b_j, e\}$ of M is replaced in M' by the block inserted in the $(\ell - j - 1)$ st face of $\text{DB}(k - 2, \chi', z')$ on the side corresponding to the position of its $(\ell - j)$ th DB-element (if the B-edge of the $(\ell - j - 1)$ st face is also on this side, then this block is closer to $(\ell - j)$ th face – to the right in the standard drawing of $\text{DB}(k - 2, \chi', z')$, but to the left in our upside down drawing).

We denote this M' by $\text{EDBL}_1(k, j, \chi, z)$. Since it is obtained from a DB-matching by inserting a block, it is an L-matching. See Figure 19(a) for an example. It also shows the general form of corresponding dual trees. The dotted line surrounding a leaf and a 2-branch indicates that these branches are on the different sides of the path.

- **Case 3b: Two pairs, $\{b_j, e'\}$ and $\{d_j, e\}$, belong to the flippable partition.** $M \setminus \{b_j, e'\}$ is the DB-matching $\text{DB}(k - 2, \chi, z)$. Its neighbor is $\text{DB}(k - 2, \chi', z')$. The flippable pair $\{b_j, e'\}$

is replaced in M' by a two D-edges. Thus, M' can be obtained from $\text{DB}(k - 2, \chi', z')$ by replacing its $(\ell - j)$ th D-edge by three D-edges.

We denote this M' by $\text{EDBL}_2(k, j, \chi, z)$. It can be obtained by inserting a block (DD) into a DB-matching consisting of $\ell - j - 1$ DB-elements (its right side), and then inserting j blocks (its left side). Therefore it is an L-matching. See Figure 19(b) for an example.

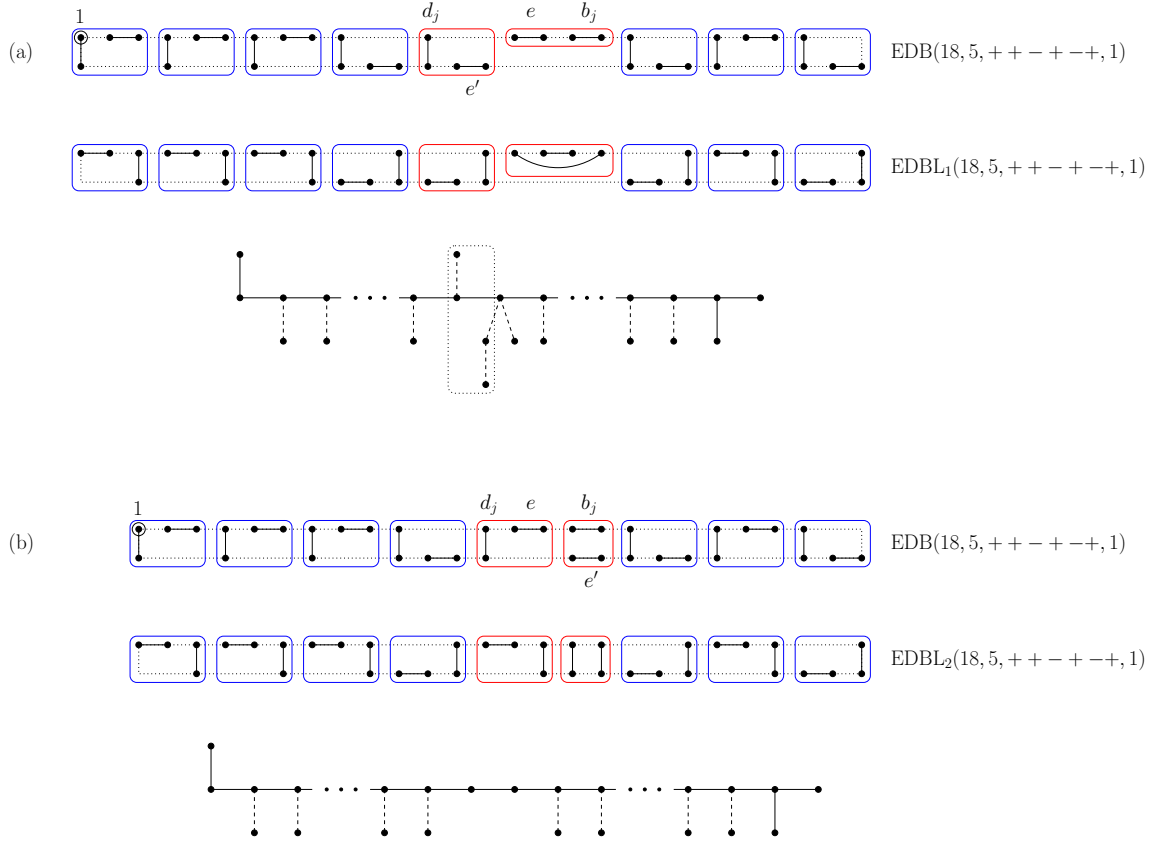

Figure 19: $\text{EDB}(18, 5, ++-+-+, 1)$ and its neighbors determined by flipping two pairs in D_j (Proposition 33, cases 3a and 3b).

□

Remark. We showed that EDBL-matchings can be obtained from DB-matchings by inserting certain elements. In some cases (listed below), when these elements are inserted close to the either of the ends, the obtained EDBL-matchings, and, correspondingly, their dual trees, have some special elements that do not present in the “regular” cases. For $j = 1$, the dual graph of EDBL_1 has a vertex of degree 4 to which two 2-branches are attached, and the dual graph of EDBL_2 a 4-branch. For $j = \ell - 1$, the dual graph of EDBL_1 and that of EDBL_2 have 3-branches. For $j = \ell - 2$, the dual graph of EDBL_1 has a vertex of degree 4 to which two leaves and one 4-branch are attached. See Figure 20 for an example and the general structure of dual trees in such cases.

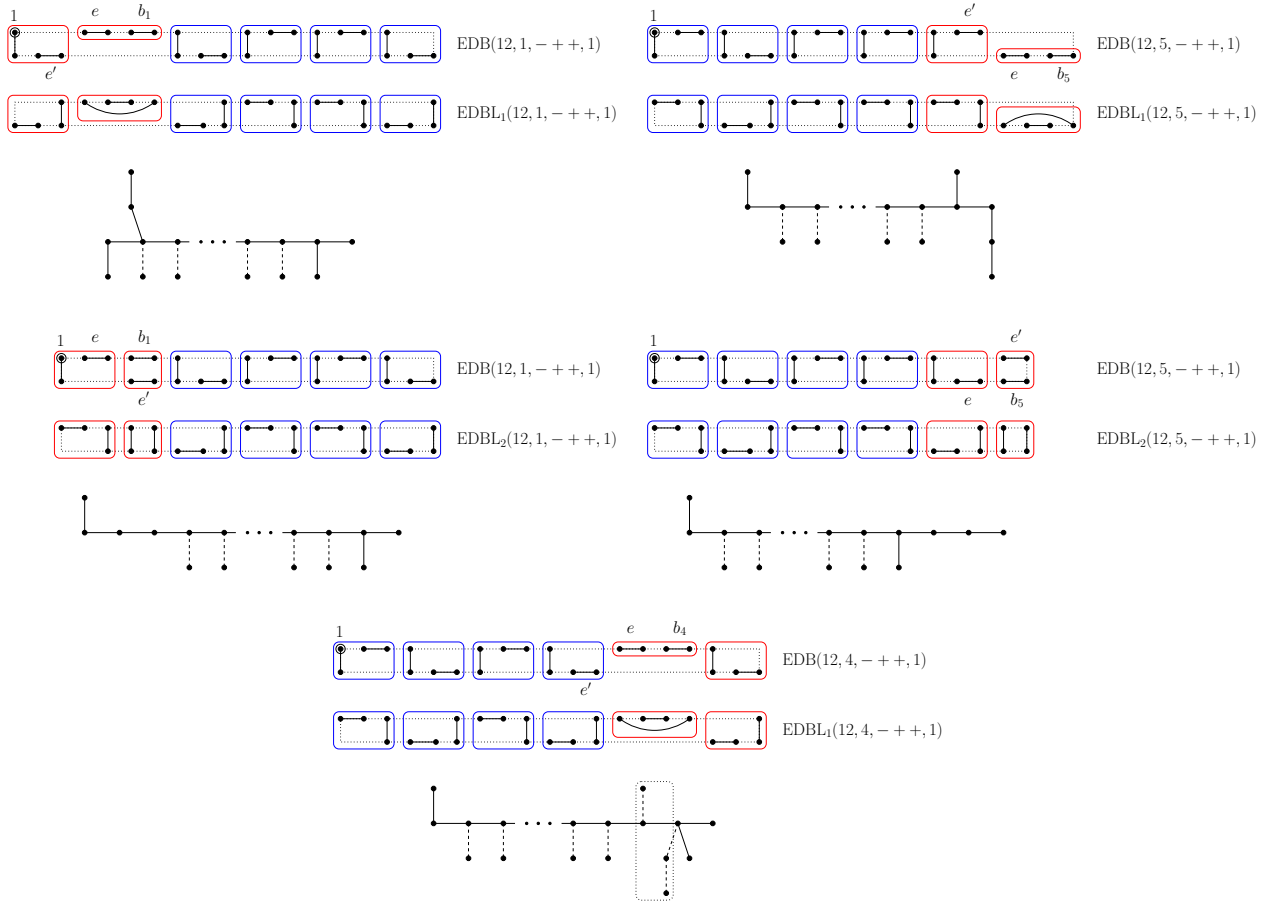

Figure 20: EDBL-matchings with special structure (Illustration to remark to Proposition 33).

Since the neighbors of an EDB-matching $M = \text{EDB}(k, j, \chi, z)$ are only EDB-matchings with parameters χ' and z' , and two L-matchings, the structure of the connected component of \mathbf{DCM}_k that contains M follows from Proposition 33.

Corollary 34. *The connected component of \mathbf{DCM}_k that contains $\text{EDB}(k, j, \chi, z)$ has the following structure:*

- There is a path P of length $k - 3$:

$$\begin{aligned} & \text{EDB}(k, 1, \chi, z) - \text{EDB}(k, \ell - 1, \chi', z') - \text{EDB}(k, 2, \chi, z) - \text{EDB}(k, \ell - 2, \chi', z') - \dots \\ & \dots - \text{EDB}(k, \ell - 2, \chi, z) - \text{EDB}(k, 2, \chi', z') - \text{EDB}(k, \ell - 1, \chi, z) - \text{EDB}(k, 1, \chi', z'); \end{aligned}$$

- There are additional edges between the matchings that belong to P , as follows:

$$\text{EDB}(k, j_1, \chi, z) - \text{EDB}(k, j_2, \chi', z')$$

for all j_1, j_2 ($1 \leq \{j_1, j_2\} \leq \ell - 1$) such that $j_1 + j_2 \geq \ell + 2$;

(Equivalently: if we denote the matchings from the path P , according to the order in which

they appear on P , by M_1, M_2, \dots, M_{k-2} , then these additional edges are all the edges of the form $M_a M_b$, where a is even, b is odd, and $a \leq b - 3$.)

- Each member of P is also adjacent to two leaves.

In particular, all such components are isomorphic, and their size is $3(k - 2)$.

Figure 21 shows such a component for $k = 12$. The labels $(12, j, \chi/\chi', z/z')$ (with “EDB” being omitted) refer to the vertices of the path P that appear directly above them.

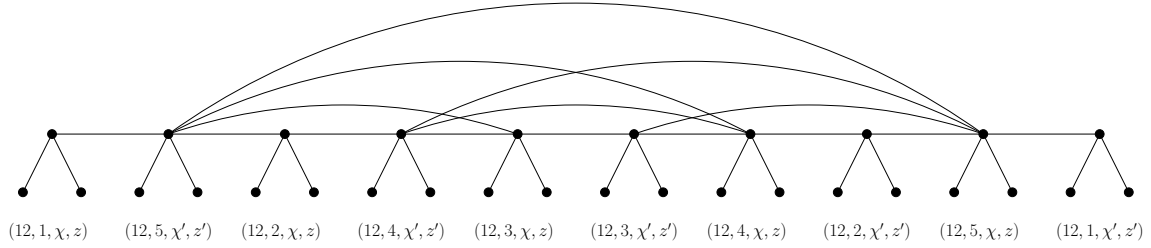

Figure 21: The structure of the connected component of \mathbf{DCM}_{12} that contains an EDB-matching.

Proposition 35. *The number of components of \mathbf{DCM}_k that contain EDB-matchings is $\ell \cdot 2^{\ell-2}$.*

Proof. By Proposition 28, the number of DB-matchings of size $k - 2$ is $(\ell - 1) \cdot 2^{\ell-1}$. Therefore, there are $2^{\ell-4}$ pairs of unlabeled DB-matchings of size $k - 2$. Each such pair produces one connected component that contains unlabeled EDB-matchings of size k . z can be chosen in $2k = 4\ell$ ways. Thus, the number of such components is $\ell \cdot 2^{\ell-2}$. \square

To summarize: In this section we described certain connected components of \mathbf{DCM}_k for even values of k . The enumerational results fit those from Table 2. In Section 5 we will show that these are precisely the medium components of \mathbf{DCM}_k for even k .

5 Big components

5.1 The survey of the proof

In Section 3 we defined I- and DB-matchings and proved that they are precisely those matchings that form small components. In Section 4 we defined DBD-, DBDL-, EDB- or EDBL-matchings and described their connected components. In order to complete the proof, we need to show that all other matchings form one (“big”) connected component. We start with some definitions.

Definitions.

1. The *ring component* of \mathbf{DCM}_k is the connected component that contains the rings.
2. A *special* matching is either an I-, DB-, DBD-, DBDL-, EDB- or EDBL-matching.
3. A *regular* matching is a matching which is not special.

Observe that for $k \geq 5$ the rings are regular matchings.

Theorem 1 follows from the results obtained above and the following theorem.

Theorem 36. *For $k \geq 9$, every regular matching M belongs to the ring component.*

Proof. For $k = 9$ and 10 , the statement was verified by a computer program. For $k \geq 11$, the proof is by induction.

By Proposition 11, M has at least one separated pair K . Let $L = M - K$. Now we have two cases depending on whether L is special or regular.

Case 1: L is regular. By induction, L belongs to the ring component in \mathbf{DCM}_{k-2} . We perform the sequence of operations that converts L into a ring, while K oscillates (that is, on the points of K , on each step a block is replaced by an antiblock, or vice versa). In this way we obtain a matching of the form $R + K'$ where R is a ring of size $k - 2$ and K' is a separated pair. We can also assume that K' is an antiblock (otherwise, if K' is a block, we flip K' and R : K' is then replaced by an antiblock, and R by the second ring). If the antiblock K' is inserted in a skip of R , then the whole obtained matching is a ring of size k , and we are done. Otherwise, the antiblock K' is inserted between two connected points of R . In such a case we use the following proposition that will be proven in Section 5.2.

Proposition 37. *For $k \geq 8$, the ring component of \mathbf{DCM}_k is not bipartite.*

Thus, it is possible to convert the ring R into the second ring by an *even* number of operations. We perform these operations, while K' oscillates. After this sequence of operations, we still have the antiblock K' , but the ring R is replaced by the second ring R' , and now the whole matching is a ring of size k . Figure 22 illustrates the last step for odd k .

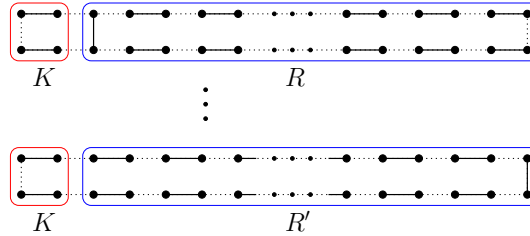

Figure 22: Illustration to the proof of Theorem 36 when L is regular.

This completes the proof of Case 1.

Case 2: L is special. In this case we use the following proposition that will be proven in Section 5.3.

Proposition 38. *Let M be a regular matching of size k ($k \geq 10$) that has a decomposition $M = L + K$ where K is a separated pair and L is a special matching. Then M has another decomposition $N + P$, where P is a separated pair and N is a **regular** matching, or M is connected (by a path) to a matching that has such a decomposition.*

Thus, M has a decomposition as in Case 1, or it is connected by a path to a matching that has such a decomposition. In both cases it means that M belongs to the ring component. This completes the proof. \square

It remains to prove Propositions 37 and 38.

5.2 The ring component is not bipartite for $k \geq 8$ (proof of Proposition 37).

We prove Proposition 37 by constructing a path of odd length from a ring to itself. In figures, we mark the matchings alternately by white and black squares, starting with a ring marked by white. We finish when we obtain the same ring marked by black.

First we prove the proposition for even values of k . For $k = 8$, it is verified directly, see Figure 23 (in this and the following figures, we use “vertical” strip drawings in order to save the space).

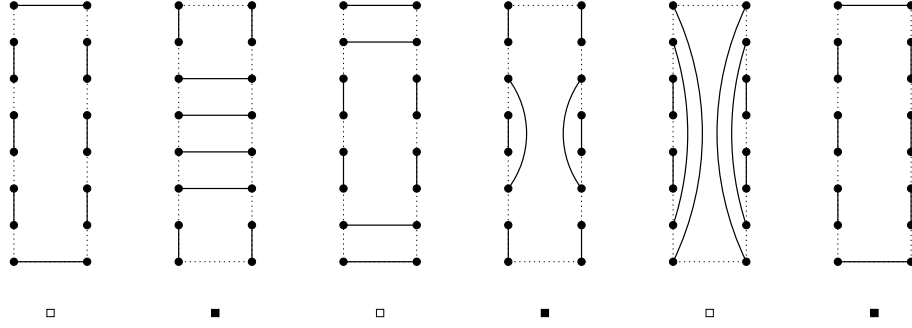

Figure 23: Proof of Proposition 37 for $k = 8$.

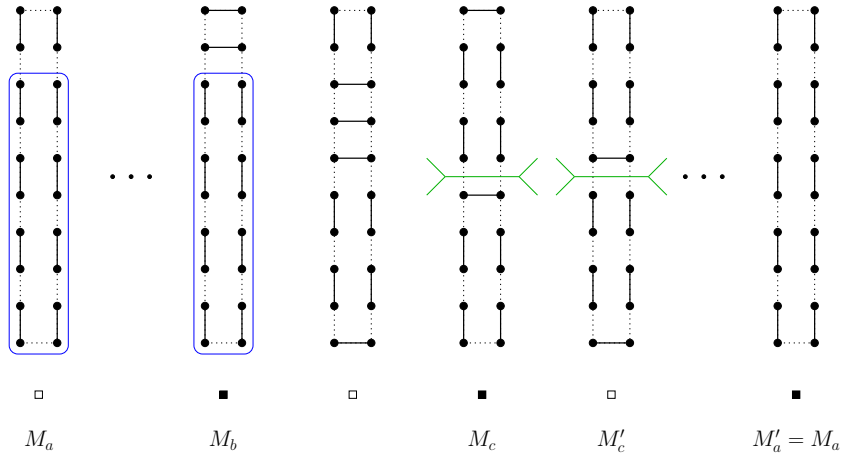

Figure 24: Proof of Proposition 37 for $k = 10$.

For $k = 10$ refer to Figure 24. We start with a ring M_a represented by a strip drawing. M_b is obtained from M_a by applying the operations as in Figure 23 on the flippable set of size 8 marked by a blue box. Since the number of these operations is odd, the block outside this flippable set is replaced by an antiblock. After the next two steps we reach a drawing M_c . For each drawing M_i on the path from M_a to M_c , denote by M'_i the reflection of M_i with respect to the green line (which halves the points). Notice that M'_c is adjacent to M_c . Therefore, we can obtain the path $M_a \dots M_b M_c M'_c M'_b \dots M'_a$. This path has odd length, and $M'_a = M_a$. Thus, we have found a path of odd length from a ring to itself.

For even $k \geq 12$ we prove the statement by induction, assuming it holds for $k - 4$ and for $k - 2$. Refer to Figure 25. We start from a ring M_a . M_b is obtained from M_a by applying the odd

number of operations which transfer the ring of size $k - 2$ to itself, on the flippable set marked by blue. M'_b is obtained from M_b by applying the odd number of operations which transfer the ring of size $k - 4$ to itself, on the flippable set marked by red boxes. Notice that M'_b is the reflection of M_b with respect to the green line (which halves the points). Therefore, we can obtain the path $M_a \dots M_b \dots M'_b \dots M'_a$, where M'_i is the reflection of M_i with respect to the green line. This path has odd length, and $M'_a = M_a$. Thus, we have found a path of odd length from M_a to itself.

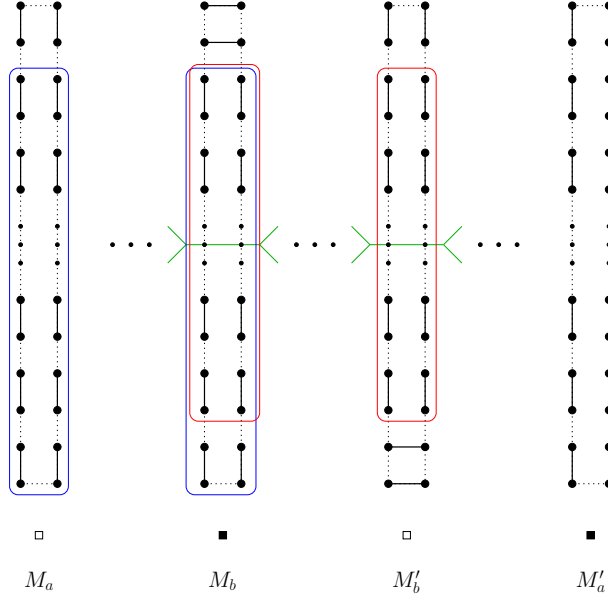

Figure 25: Proof of Proposition 37 for even $k \geq 12$.

Now we prove the proposition for odd values of k . For $k = 9$, it is verified directly. Refer to Figure 26. We start from a ring M_a , and after four steps we reach a matching M_c which is symmetric with respect to the green line. Therefore we can construct a path of even size $M_a \dots M_b M_c M'_b \dots M'_a$, where M'_i the reflection of M_i with respect to the green line. M'_a is the second ring, which is disjoint compatible to M_a , and, thus we have a path of odd length from M_a to itself.

For odd $k \geq 11$, we prove the statement using the even case proven above. Refer to Figure 27. We start from a ring M_a . M_b is obtained from M_a by applying an odd number of operations on the flippable set of size $k - 3$ marked by blue, while the remaining flippable triple oscillates. After two more steps we reach a matching M_d , which is symmetric with respect to the green line. Therefore we can construct a path of even size $M_a \dots M_b M_c M_d M'_c M'_b \dots M'_a$, where M'_i is the reflection of M_i with respect to the green line. M'_a is the second ring which is disjoint compatible to M_a . Thus we have a path of odd length from M_a to itself. \square

Remark. We have verified by direct inspection and a computer program that for $2 \leq k \leq 7$, the ring component of \mathbf{DCM}_k is bipartite.

5.3 Proof of Proposition 38

We restate the claim to be proven in this section.

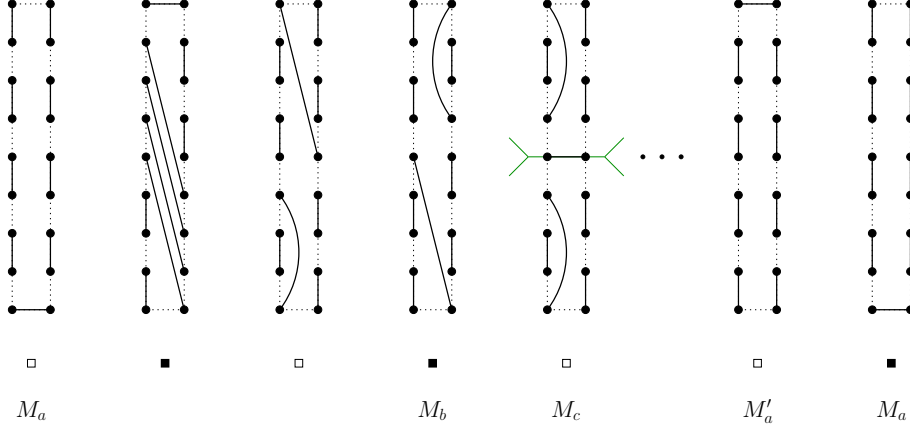

Figure 26: Proof of Proposition 37 for $k = 9$.

Proposition 38. *Let M be a regular matching of size k ($k \geq 10$) that has a decomposition $M = L + K$ where K is a separated pair and L is a special matching. Then M has another decomposition $N + P$, where P is a separated pair and N is a **regular** matching, or M is connected (by a path) to a matching that has such a decomposition.*

Overview of the proof. In the proof to be presented, the possible structure of L plays the central role, and we need to refer to the definitions and standard notation of some kinds of special matchings. Therefore we replace k by $k - 2$, and assume from now on that L is a matching of size k and M is a matching of size $k + 2$, where $k \geq 8$.

Since the special matchings have different structure for odd and even values of k , the proofs for these cases are separate. It is more convenient to follow the proofs if we use dual graphs. In order to simplify the exposition, the elements of the dual graphs that correspond to blocks and antiblocks – 2-branches and V-shapes – will be occasionally referred to just as blocks and antiblocks.

The idea of the proof is similar to that of the $[\Rightarrow]$ -part in the proof of Theorem 27. It is given that L is a special matching. For some kinds of special matchings we shall proceed as follows. Depending on the point where K is inserted into L (or, in terms of dual trees, $D(K)$ is attached to $D(L)$), we shall choose P and show that for this choice the matching $N = M - P$ does not fit any of the structures of special matchings (of appropriate parity). Therefore, N must be regular, and, thus M has a desired decomposition. For other kinds of special matchings we shall use the structure of components that contain special matchings in order to show that M is connected (by a path) to a matching that has a desired decomposition.

5.3.1 Proof of Proposition 38 for odd k .

First, we recall all possible structures of dual trees of DBD- and DBDL-matchings, and the standard notation for DBD-matchings. The dual trees of DBDL-matchings have two possible structures referred to as DBDL1 and DBDL2, see Figure 28. Moreover, we recall that I-matchings never have antiblocks (Proposition 18), and that for $k \geq 5$ they have at least two disjoint blocks (Proposition 17).

Case 1. L is a DBD-matching, K is a block. Refer to the first graph in Figure 28 as to the dual tree of L . Due to the symmetry of DBD-matchings, we can assume that $D(K)$ is attached to $D(L)$

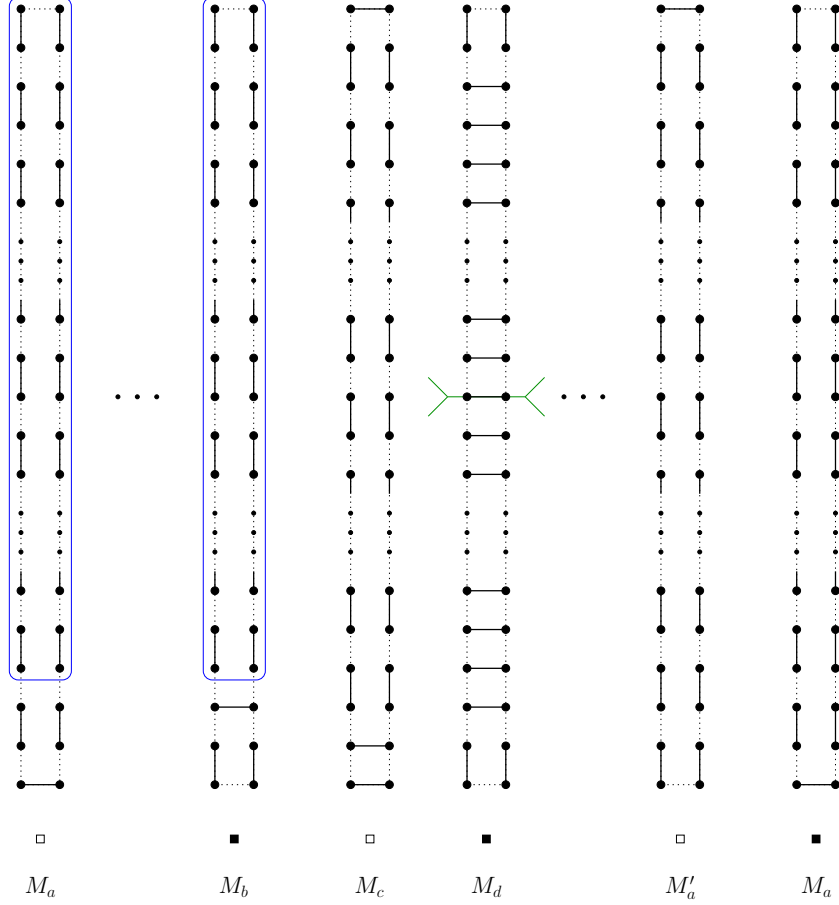

Figure 27: Proof of Proposition 37 for odd $k \geq 11$.

in the point B_i or D_i where $i \leq \lceil \frac{\ell-1}{2} \rceil$. Let P be the antiblock $B_\ell D_{\ell-1} B_{\ell-1}$, and let $N = M - P$. Then N is a regular matching. Indeed, N has an antiblock $(D_{\ell-1} D_{\ell-2} B_{\ell-2})$, and thus it cannot be an I-matching. If $D(K)$ is attached in B_i , then $D(N)$ has a 3-branch, which never happens for DBD- and DBDL-matchings. If $D(K)$ is attached in D_i , then $D(N)$ has a vertex of degree 4 to which at most two leaves are attached, which never happens for DBD- and DBDL-matchings.

Case 2. L is a DBD-matching, K is an antiblock. Again we assume that $D(K)$ is attached to $D(L)$ in the point B_i or D_i where $i \leq \lceil \frac{\ell-1}{2} \rceil$. Denote by P the antiblock $B_\ell D_{\ell-1} B_{\ell-1}$, and let $N = M - P$. Then N is a regular matching. Indeed, N cannot be an I-matching because it has at least one antiblock. If $D(K)$ is attached in B_0 or B_1 , then M is special (DBD), while it is assumed to be regular. If $D(K)$ is attached in B_i , $i \geq 2$, then $D(N)$ has three disjoint antiblocks $(K, B_0 D_1 B_1$ and $D_{\ell-1} D_{\ell-2} B_{\ell-2})$, which never happens for DBD- and DBDL-matchings. If $D(K)$ is attached in D_i , then $D(N)$ has a vertex of degree 5 and has no blocks, which never happens for DBD- and DBDL-matchings.

Case 3. L is a DBDL-matching, K is a separated pair. Such a matching M is adjacent to a matching $M' = L' + K'$ where L' is the DBD-matching adjacent to L , and K' is the flip of K . For M' the statement holds by Cases 1 and 2. Therefore, it also holds for M .

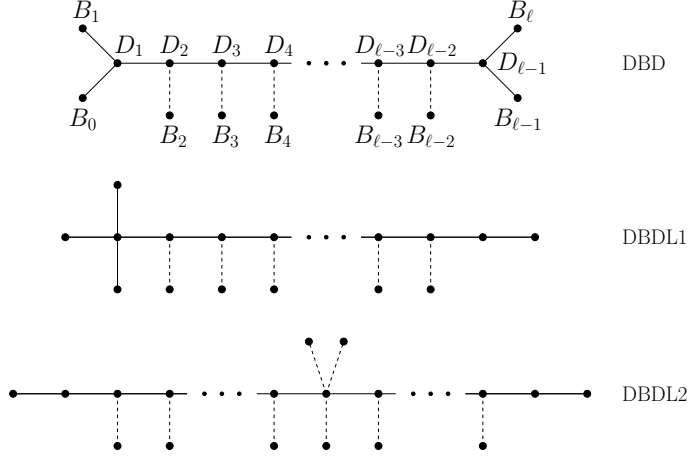

Figure 28: Dual trees of odd size special matchings from medium components.

Case 4. L is an I-matching, K is a block. In such a case M is also an I-matching (by Theorem 27), and, thus, it cannot be regular. So, this case is impossible.

Case 5. L is an I-matching, K is an antiblock. L has at least two disjoint blocks. Therefore, M has at least one block K' . Clearly, K' is disjoint from K . Denote $L' = M - K'$. L' cannot be an I-matching because it has an antiblock (K). If L' is a DBD- or a DBDL-matching, we return to Case 1 or 3 (with L' and K' in the role of L and K). If L' is regular, we are done. \square

5.3.2 Proof of Proposition 38 for even k .

We recall all possible structures of the dual trees of DB-, EDB- and EDBL-matchings. As we saw in Section 4.2, the dual tree of any EDB-matching has one of three possible structures, and the dual tree of any EDBL-matching has one of six possible structures; these structures will be referred to as in Figure 29 (EDB1, EDB2, etc.). For dual trees of DB-matchings and of EDB1-matchings (that is, the EDB-matchings in which the edges e and e' belong to the face D_j where $2 \leq j \leq \ell - 2$), we also recall the standard notation of vertices.

Case 1. L is a DB-matching. Refer to the labeling of $D(L)$ as in Figure 29. $D(K)$ is attached to $D(L)$ in some point B_i or D_i . If $i \geq \lceil \frac{\ell}{2} \rceil$, let P be the antiblock $B_0 D_1 B_1$. If $i < \lceil \frac{\ell}{2} \rceil$, let P be the block $D_{\ell-1} D_\ell B_\ell$. Denote $N = M - P$. We claim that N is regular.

In the case $i \geq \lceil \frac{\ell}{2} \rceil$, in the left side of $D(N)$ we have an antiblock $B_2 D_2 D_1$, and D_2 has degree 3. Therefore, if N is special, it can be only an antiblock Q that appears in the left side of DB, EDB1, EDB3, EDBL1, EDBL2, EDBL4 or EDBL5 (it is marked by a red frame in Figure 29). However, in such a case, upon restoring $D(P)$ (attaching it to one of the leaves of Q) we obtain a matching that fits the same structure, and therefore, is also special. This is a contradiction since $M = N + P$ is a regular matching.

In the case $i < \lceil \frac{\ell}{2} \rceil$ the reasoning is similar: in the right side of $D(N)$ we have a block $D_{\ell-2} D_{\ell-1} B_{\ell-1}$. and $D_{\ell-2}$ has degree 3. Therefore, if N is special, it can be only a block R that appears in the right side of DB, EDB1, EDB2, EDBL1, EDBL2, EDBL3 or EDBL6 (it is marked by a blue frame in Figure 29). Upon restoring $D(P)$ (attaching it to the central point of R) we obtain a matching that fits the same structure, and therefore, is also special. This is a

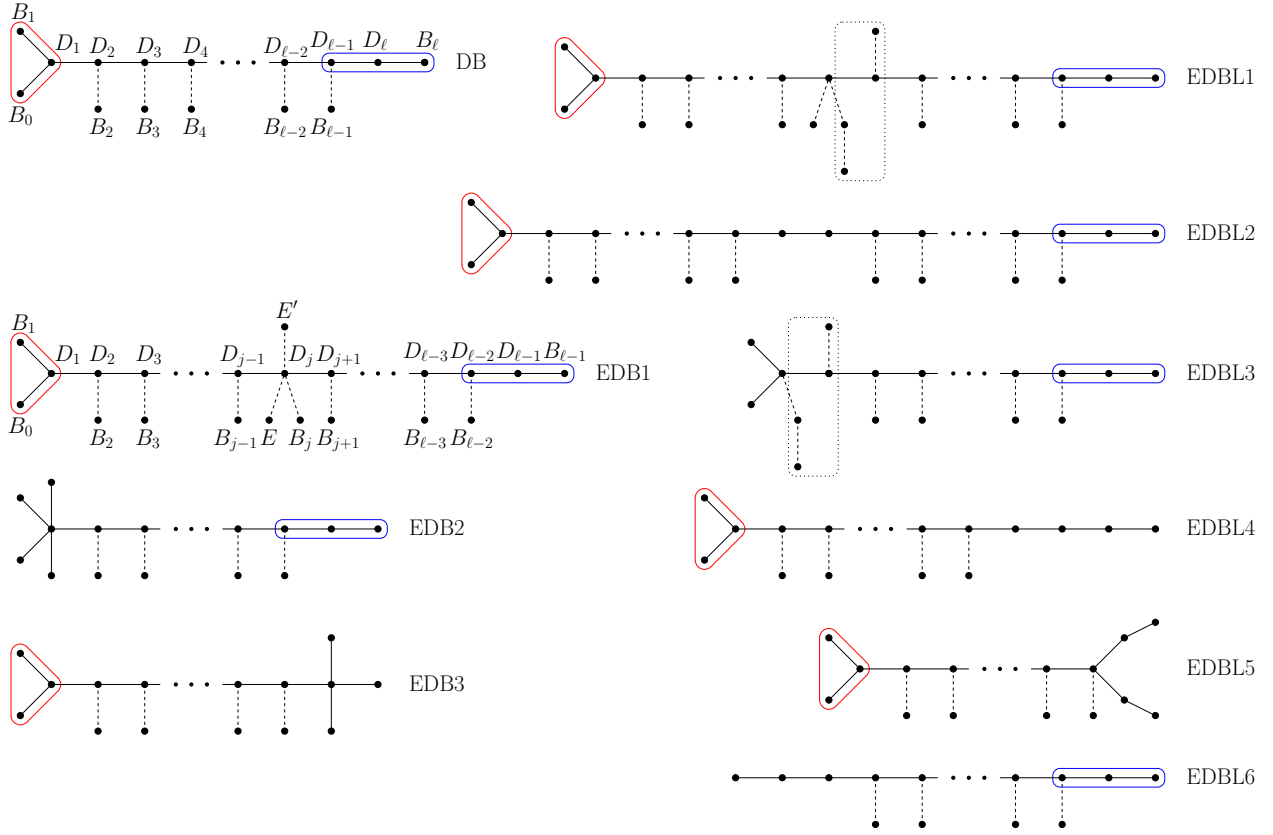

Figure 29: Dual trees of small and medium special matchings.

contradiction as above.

Case 2. L is an EDB1-matching with $j = \left\lceil \frac{\ell-1}{2} \right\rceil$. Refer to the labeling of $D(L)$ as in Figure 29. The proof is similar to that of Case 1. If $D(K)$ is attached to $D(L)$ “in the right part” – that is, in B_i or D_i with $i \geq j$, or in one of the points E, E' , – we take P to be the leftmost antiblock. If $D(K)$ is attached to $D(L)$ “in the left part” – that is, in B_i or D_i with $i < j$, – we take P to be the rightmost block. We assume (for contradiction) that $N = M - P$ is special. However, depending on the case, $D(N)$ has an antiblock or a block with a vertex of degree 3. Therefore it can fit a special matching in a specific way. Upon restoring P , we see that $D(M)$ fits the same structure as $D(N)$, and, therefore, M is special – a contradiction.

Case 3. L is an EDB-matching not of the kind treated in Case 2, or an EDBL-matching. By Corollary 34, L is connected by a path to a matching L' of the kind treated in Case 2. Therefore, $M = L + K$ is connected by a path to $M' = L' + K'$ where K' is either K or its flip. As we saw in Case 2, M' has a desired decomposition, therefore, the statement of Theorem holds for M .

We have verified all the cases, and, so, the proof is complete. \square

5.4 The order of the ring component

In Introduction, the ring component was referred to as the “big component”. In order to show that it indeed has the biggest order, we need to compare its order with that of medium components.

Proposition 39. *For each $k \geq 9$, the order of the ring component is larger than the order of the components that contain DBD- (for odd k) or, respectively EDB- (for even k) matchings.*

Proof. Since the total number of vertices in \mathbf{DCM}_k is C_k , and we know the order and the number of all other components, we obtain that the for odd k the order of the ring component of \mathbf{DCM}_k is

$$C_{2\ell-1} - 1 \cdot \frac{1}{\ell} \binom{4\ell-2}{\ell-1} - \ell \cdot (2\ell-1)2^{\ell-3},$$

and for even k it is

$$C_{2\ell} - 2 \cdot \ell 2^{\ell-1} - (6\ell-6) \cdot \ell 2^{\ell-2}.$$

Thus, we need to show that for odd $k \geq 9$ we have

$$C_{2\ell-1} - \frac{1}{\ell} \binom{4\ell-2}{\ell-1} - \ell(2\ell-1)2^{\ell-3} > \ell,$$

or, equivalently,

$$C_{2\ell-1} > \frac{1}{\ell} \binom{4\ell-2}{\ell-1} + \ell(2\ell-1)2^{\ell-3} + \ell; \quad (3)$$

and that for even $k \geq 10$ we have

$$C_{2\ell} - \ell 2^\ell - \ell(6\ell-6)2^{\ell-2} > 6\ell-6,$$

or, equivalently,

$$C_{2\ell} > \ell 2^\ell + \ell(6\ell-6)2^{\ell-2} + 6\ell-6. \quad (4)$$

First, notice that Inequalities (3) and (4) hold asymptotically since the growth rate of $(C_{2\ell-1})_{\ell \geq 1}$ and of $(C_{2\ell})_{\ell \geq 1}$ is 16; that of $\left(\frac{1}{\ell} \binom{4\ell-2}{\ell-1}\right)_{\ell \geq 1}$ is $\frac{256}{27} \approx 9.48$; and that of other terms is at most 2. In order to show that they hold for $k \geq 9$, we verify them for $\ell = 5$, and show that for $\ell \geq 5$ we have $\frac{\text{RHS}_{\ell+1}}{\text{RHS}_\ell} < 10$ and $\frac{\text{LHS}_{\ell+1}}{\text{LHS}_\ell} > 10$ in them both.¹⁴ We omit further details. \square

6 More enumerating results, concluding remarks, and open problems

6.1 Vertices with largest degree

In Section 3 we characterized matchings with smallest possible degrees (as vertices of \mathbf{DCM}_k): 0 and 1. One can expect that the matchings with the largest degree are the rings. Here we show that this is indeed the case.

¹⁴ *LHS* and *RHS* denote the *left-hand side* and the *right-hand side* of the respective inequalities.

Proposition 40. *For each $k > 1$, the vertices of \mathbf{DCM}_k with the maximum degree are precisely those corresponding to the rings. Their degree is the k th Riordan number,*

$$r_k = \frac{1}{k+1} \sum_{i=1}^{\lfloor \frac{k}{2} \rfloor} \binom{k+1}{i} \binom{k-i-1}{i-1}. \quad (5)$$

Proof. Let M be any matching of size k which is not a ring. Let $e = P_\alpha P_\beta$ be a diagonal edge of M . Modify the point set X_{2k} by transferring P_β to the position between P_α and $P_{\alpha+1}$ (on Γ). Denote the modified point set by X'_{2k} . Let M' be the matching of X'_{2k} whose members connect the pairs of points with the same labels as M . It is easy to see that M' is a non-crossing matching, and that each flippable partition of M (given by labels of endpoints of edges) is a flippable partition of M' . Therefore $d(M) \leq d(M')$. We repeat this procedure until we eventually reach a ring R . Thus, we have $d(M) \leq d(R)$. Moreover, since the partition that consists of one set (whose members are all the edges) is flippable in R but not in M , we have in fact $d(M) < d(R)$.

In order to find $d(R)$, we proceed as follows. Assume that R is the ring with edges $P_1 P_2, P_3 P_4, \dots, P_{2k-1} P_{2k}$. For each $1 \leq i \leq k$, contract the edge $P_{2i-1} P_{2i}$ into the point P_{2i} . The induced modification of flippable partitions of R is a bijection between flippable partitions of R and non-crossing partitions of $\{Q_1, Q_2, \dots, Q_k\}$ without singletons. The partitions of the latter type are known to be enumerated by Riordan numbers [25, A005043]. See [7] for bijections between this structure and other structures enumerated by Riordan numbers. The explicit formula for the k th Riordan numbers is as in Eq. (5) (see [10] for a simple combinatorial proof), and asymptotically $r_k = \Theta^*(3^k)$. \square

6.2 Number of edges

In this section we consider enumeration of edges of \mathbf{DCM}_k . Denote, for $k \geq 1$, the number of edges in \mathbf{DCM}_k by d_k ; moreover, set $d_0 = 1$. Let $z(x)$ be the corresponding generating function $z(x) = \sum_{k \geq 0} d_k x^k$, and let $Z(x) = 2z(x) - 1$.

Proposition 41. *The function $Z(x)$ satisfies the equation*

$$Z(x) = 1 + \frac{2x^2 Z^4(x)}{1 - xZ^2(x)}. \quad (6)$$

Moreover, $d_k = \Theta^*(\mu^n)$ with $\mu \approx 5.27$.

Proof. Any edge e of \mathbf{DCM}_k corresponds to a pair of disjoint compatible matchings – say, M_a and M_b . By Observation 4, $M_a \cup M_b$ is a union of pairwise disjoint cycles that consist alternately of edges of M_a and M_b . We can color them by blue and red, as in Figure 3. If we ignore the colors, these cycles form a non-crossing partition of X_{2k} into even parts of size at least 4. Given such a partition, each polygon can be colored alternately by two colors in two ways. Each way to color alternately all the polygons in such a partition corresponds to an edge of \mathbf{DCM}_k . However, in this way each edge is created twice because exchanging all the colors results in the same edge. Since each part in the partition can be colored in two ways, the total number of edges of \mathbf{DCM}_k is equal to the number of non-crossing partitions of X_{2k} into even parts of size at least 4, when each partition is counted 2^{p-1} times, where p is the number of parts. Equivalently, $H(x)$ is the

generating function for the number of such partitions of X_{2k} where each part is colored by one of two colors. Since the part that contains 1 is a polygon of even size at least 4, and the skip between any pair of consecutive points of this polygon possibly contains further partition of the same kind, we have

$$Z(x) = 1 + 2x^2Z^4(x) + 2x^3Z^6(x) + 2x^4Z^8(x) + 2x^5Z^{10}(x) + \dots,$$

which is equivalent to Eq. (6).

We can estimate the asymptotic growth rate of $(d_k)_{k \geq 0}$ as follows. By the Exponential Growth Formula (see [12, IV.7]), for an analytic function $f(x)$ the asymptotic growth rate is $\mu = \frac{1}{\lambda}$, where λ is the absolute value of the singularity of $f(x)$ closest to the origin. It is easier to find λ for $Y(x) = xZ(x)$. From Eq. (6) we have

$$2Y^4(x) + Y^3(x) - xY^2(x) - xY(x) + x^2 = 0.$$

This is a square equation with respect to x ; solving it we obtain that $Y(x)$ is the compositional inverse of

$$V(x) = \frac{x}{2} \left(1 + x + \sqrt{1 - 2x - 7x^2} \right).$$

The singularity points of $Y(x)$ correspond to the points where the derivative of $V(x)$ vanishes. Analyzing $V(x)$, we find that the singularity point of $Y(x)$ with the smallest absolute value is $\lambda \approx 0.1898$. Therefore, the asymptotic growth rate of $(d_k)_{k \geq 0}$ is $\mu \approx 5.2680$. \square

6.3 “Almost perfect” matchings for odd number of points

In this section we consider, without going into details, the following variation. Let X_{2k+1} be a set of $2k + 1$ points in convex position. In this case we can speak about *almost perfect* (non-crossing straight-line) matchings – matchings of $2k$ out of these points, one point remaining unmatched. Clearly, the number of such matchings is kC_k . The definition of disjoint compatibility and that of disjoint compatibility graph are carried over for this case in a straightforward way. In contrast to the case of perfect matchings of even number of points, we have here the following result.

Claim 42. *For each k , the disjoint compatibility graph of almost perfect matchings of $2k + 1$ points in general position is connected.*

This claim can be proven along the following lines. For $k = 1, 2$, it is verified directly. For $k \geq 3$, we apply induction similarly to that in the proof of Theorem 36. The *rings* in this case are the matchings that contain only boundary edges and one unmatched point. For fixed k , there are exactly $2k + 1$ rings that are uniquely identified by their unmatched point. Denote by R_j the ring whose unmatched point is P_j . Then the ring R_j is disjoint compatible to exactly two rings, namely, R_{j-1} and R_{j+1} . Thus, the rings induce a cycle of size $2k + 1$.

Let M be an almost perfect matching, and let P be the unmatched point. We show that M is connected by a path to the rings as follows. It is always possible to find a separated pair K which is not interrupted by P (suppose that K connects the points $P_i, P_{i+1}, P_{i+2}, P_{i+3}$). We let K oscillate, while transforming $L = M - K$ into a ring R (on $2k - 3$ points). It is possible to assume that after this process K is replaced by an antiblock K' . Now either $K' + R$ is a ring and we are done, or R has the edge $P_{i-1}P_{i+4}$. In the latter case we continue the reconfiguration: K' continues to oscillate, while we “rotate” R so that its unmatched point moves clockwise. Eventually, we will reach two matchings in which R is replaced by rings whose unmatched points are P_{i-1} and P_{i+4} . For one of them, we still have the antiblock K' , and the whole matching is a ring.

6.4 Summary and open problems

We showed that for sets of $2k$ points in convex position the disjoint compatibility graph is always disconnected (except for $k = 1, 2$). Moreover, we proved that for $k \geq 9$ there exist exactly three kinds of connected components: small, medium and big. For each k we found the number of components of each kind. For small and medium components, we determined precisely their structure.

For sets of points **in general position**, the disjoint compatibility graph depends on the order type. Therefore only some questions concerning the structure can be asked in general. We suggest the following problems for future research.

1. **Connectedness for a general point set.** What is more typical for set of points in general position: being the disjoint compatibility graph connected or disconnected? The former possibility can be the case since, intuitively, one of the reasons for the disconnectedness when the points are in convex position is the fact that all edges connect two points that lie on the boundary of the convex hull. One can conjecture, for example, that the disjoint compatibility graph is connected if the fraction of points in the interior of the convex hull is not too small.
2. **Isolated matchings.** In order to construct isolated matchings for sets of points not only in convex position, we can use the following recursive procedure. First, any matching of size 1 is isolated. Next, let $M = M_1 \cup \{e\} \cup M_2$, where M_1 and M_2 are isolated matchings, and the edge e blocks the visibility between M_1 and M_2 (see Figure 30(a)). Then it is easy to see that M is also isolated. For matchings of points in convex position, this construction gives all isolated matchings: indeed, one can easily show that for this case this construction is equivalent to that from the definition of I-matchings (see Section 3.2). However, for points in general (not convex) position it is possible to find an isolated matching that cannot be obtained by this recursive procedure: see Figure 30(b).

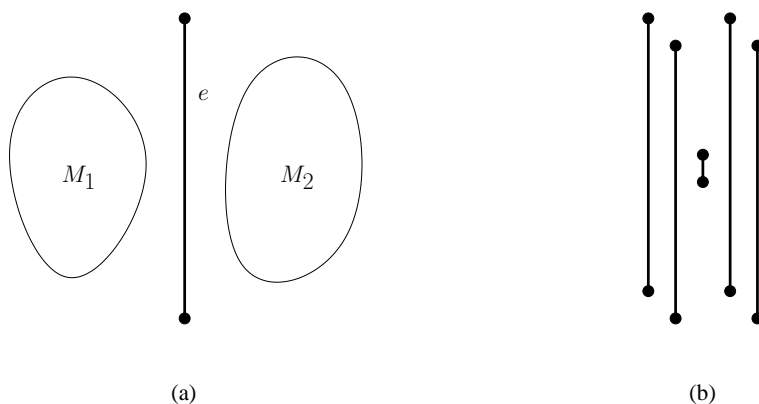

Figure 30: (a) A recursive construction of isolated matchings. (b) An isolated matching that cannot be obtained by this construction.

Acknowledgments

Research on this paper was initiated while Tillmann Miltzow was visiting the Institute for Software Technology of the University of Technology Graz. We would like to thank Thomas Hackl, Alexander Pilz and Birgit Vogtenhuber for valuable discussions and comments. Research of Oswin Aichholzer is supported by the ESF EUROCORES programme EuroGIGA, CRP ‘ComPoSe’, Austrian Science Fund (FWF): I648-N18. Research of Andrei Asinowski is supported by the ESF EUROCORES programme EuroGIGA, CRP ‘ComPoSe’, Deutsche Forschungsgemeinschaft (DFG), grant FE 340/9-1.

References

- [1] O. Aichholzer, S. Bereg, A. Dumitrescu, A. García, C. Huemer, F. Hurtado, M. Kano, A. Márquez, D. Rappaport, S. Smorodinsky, D. L. Souvaine, J. Urrutia, and D. Wood. Compatible geometric matchings. *Comput. Geom.*, 42 (2009), 617–626.
- [2] O. Aichholzer, F. Aurenhammer, and F. Hurtado. Sequences of spanning trees and a fixed tree theorem. *Comput. Geom.*, 21 (2002), 3–20.
- [3] O. Aichholzer, L. Barba, T. Hackl, A. Pilz, and B. Vogtenhuber. Linear transformation distance for bichromatic matchings. *Manuscript*, 2013; arXiv:1312.0884 [cs.CG].
- [4] O. Aichholzer, A. García, F. Hurtado, and J. Tejel. Compatible matchings in geometric graphs. Proceedings of the XIV Encuentros de Geometría Computacional (2011), 145–148.
- [5] G. Aloupis, L. Barba, S. Langerman, and D. L. Souvaine. Bichromatic Compatible Matchings. Proceedings of the 29th annual Symposium on Computational Geometry (2013), 267–276.
- [6] A. Asinowski, T. Miltzow, and G. Rote. Quasi-parallel segments and characterization of unique bichromatic matchings. Proceedings of the 29th European Workshop on Computational Geometry (2013), 225–228.
- [7] F. R. Bernhart. Catalan, Motzkin, and Riordan numbers. *Discrete Math.*, 204 (1999), 73–112.
- [8] W. G. Brown. Historical note on a recurrent combinatorial problem. *Amer. Math. Monthly*, 72:9 (1965), 973–977.
- [9] L. Cantini and A. Sportiello. Proof of the Razumov-Stroganov conjecture. *J. Combin. Theory Ser. A*, 118:5 (2011), 1549–1574.
- [10] W. Y. C. Chen, E. Y. P. Deng, and L. L. M. Yang. Riordan paths and derangements. *Discrete Math.*, 308:11 (2008), 2222–2227
- [11] H. M. Finucan. Some decompositions of generalized Catalan numbers. Combinatorial Mathematics IX. Proceedings of the 9th Australian Conference on Combinatorial Mathematics (Brisbane, August 1981). Ed.: E. J. Billington, S. Oates-Williams and A. P. Street. Lecture Notes Math., 952. Springer-Verlag, 1982, 275–293.
- [12] P. Flajolet and P. Sedgewick. Analytic Combinatorics. Cambridge University Press, 2009.

- [13] P. Di Francesco, P. Zinn-Justin, and J.-B. Zuber. A bijection between classes of Fully Packed Loops and plane partitions. *Electron. J. Combin.*, 11 #R64 (2004).
- [14] N. Fuss. Solutio quaestionis, quot modis polygonum n laterum in polygona m laterum per diagonales resolvi queat. *Nova Acta Academiae Scientiarum Imperialis Petropolitanae*, IX (1791), 243–251.
- [15] A. García, M. Noy, and J. Tejel. Lower bounds for the number of crossing-free subgraphs of K_n . *Comput. Geom.*, 16 (2000), 211–221.
- [16] C. Hernando, F. Hurtado, and M. Noy. Graphs of non-crossing perfect matchings. *Graphs and Combinatorics*, 18 (2002), 517–532.
- [17] M. E. Houle, F. Hurtado, M. Noy, and E. Rivera. Graphs of triangulations and perfect matchings. *Graphs and Combinatorics*, 21 (2005), 325–331.
- [18] F. Hurtado. Flipping edges in triangulations. *Discrete Comput. Geom.*, 22:3 (1999), 333–346 .
- [19] M. Ishaque, D. L. Souvaine and C. D. Tóth. Disjoint Compatible Geometric Matchings. *Discrete Comput. Geom.*, 49:1 (2013), 89–131.
- [20] J. Propp. The many faces of alternating-sign matrices. In *Discrete Models: Combinatorics, Computation, and Geometry*, Volume AA of DMTCS Proceedings (2001), 43–58.
- [21] A. Razen. Crossing-Free Configurations on Planar Point Sets. Dissertation, ETH Zurich, No. 18607, 2009. <http://dx.doi.org/10.3929/ethz-a-005902005>. Also in: A lower bound for the transformation of compatible perfect matchings. Proceedings of the 24th European Workshop on Computational Geometry (2008), 115–118.
- [22] A. V. Razumov and Yu. G. Stroganov. Combinatorial nature of ground state vector of $O(1)$ loop model. *Theor. Math. Phys.*, 138:3 (2004), 333–337.
- [23] M. Sharir and W. Welzl. On the number of crossing-free matchings, cycles, and partitions. *SIAM J. Comput.* 36:3 (2006), 695–720.
- [24] R. P. Stanley. *Enumerative Combinatorics. Volume 2.* Cambridge University Press, 1999.
- [25] *The On-Line Encyclopedia of Integer Sequences*, <http://oeis.org/> .
- [26] H. N. V. Temperley and E. H. Lieb. Relations between the ‘percolation’ and ‘colouring’ problem and other graph-theoretical problems associated with regular planar lattices: some exact results for the ‘percolation’ problem. *Proc. R. Soc. Lond. Ser. A Math. Phys. Sci.*, 322:1549 (1971), 251–280.
- [27] B. Wieland. Large dihedral Symmetry of the set of alternating sign matrices. *Electron. J. Combin.*, 7 #R37 (2000).